

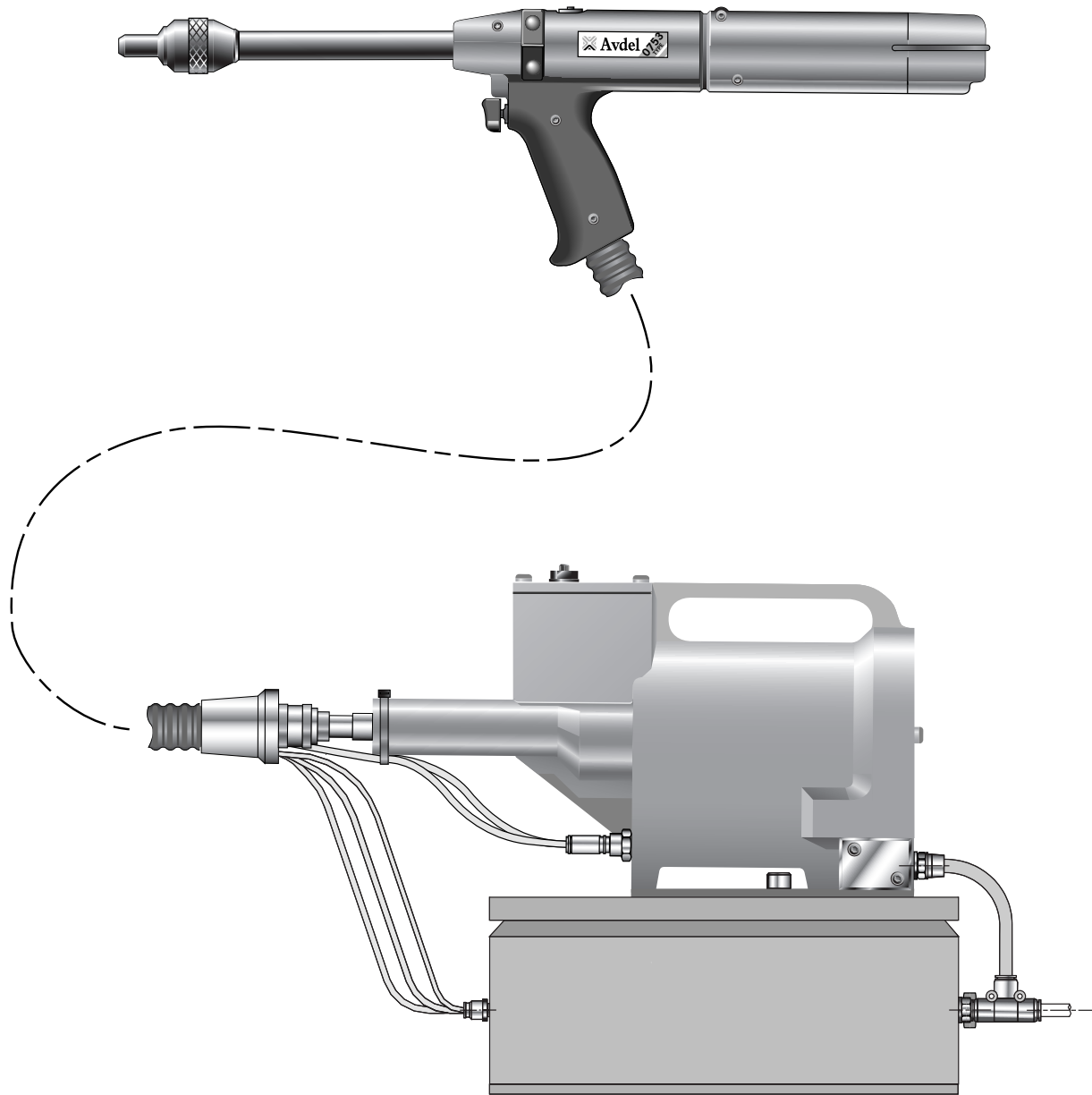

Nose Equipment Data Sheet

Original Instruction



07536

Hydro-Pneumatic Power Tool



Air Cursors

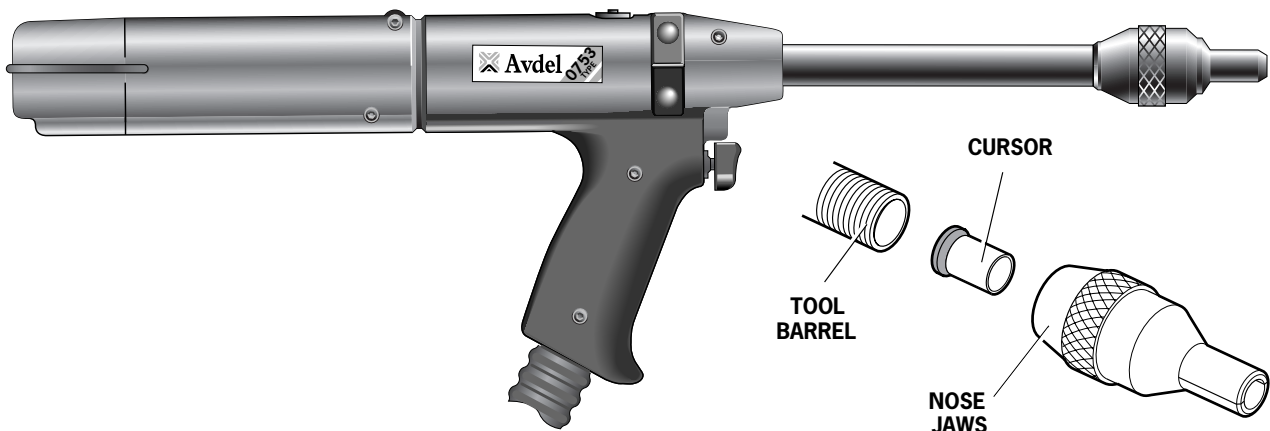

AIR CURSOR SELECTION - Reusable / Disposable

PRODUCT	MANDREL TYPE	AIR CURSOR PART NUMBER
1/16" AVLUG®	REUSABLE	07536-04100

Mandrels

MANDREL FOLLOWER SPRINGS IDENTIFICATION AND ORIENTATION

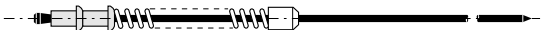
FASTENER		NOSE JAW (SEE NOSE EQUIPMENT SECTION)	MANDREL SIZE	MANDREL/MANDREL FOLLOWER SPRING AND FASTENER ASSEMBLY
NAME	SIZE			
AVLUG®	1/16"	LIMITED ACCESS	ALL	

Nose Assemblies

On speed fastening tools such as 07536, the nose equipment always consists of three elements: a nose jaw, a mandrel and a mandrel follower spring. All three items are matched to the fastener being placed and to the hole size in the application.

Orientation of the Cursor

While the cursor will be fitted the correct way round when the tool is supplied, we recommend that you check its orientation before fitting the nose equipment. The slightly concave end of the cursor should point towards the front of the tool as shown in the illustration.

To reverse the orientation of the cursor, follow these steps:

Extreme caution must be exercised when undertaking the following procedure. Care must be taken to avoid both the barrel and the protruding mandrel. Items in bold refer to the illustration on page 3.

- Remove the Nose Assembly if there is one.
- Insert an empty mandrel fully into the tool.
- Close the Tail Jaws **32** (Detail 'A' on page 3), by switching on the tail jaw switch (items **18** and **19** on Detail 'A' on page 3).
- The cursor will pop out of the barrel after a short delay.
- Open the Tail Jaws **32**, by switching off the tail jaw switch (items **18** and **19**), this will release the mandrel.
- Remove the cursor from the mandrel and insert the cursor into the barrel.

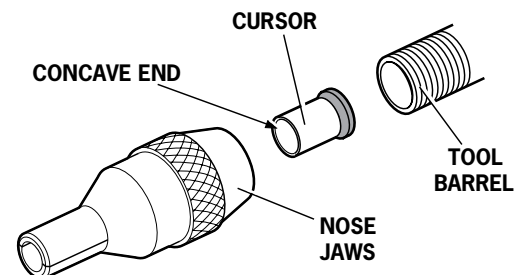

IMPORTANT

It is essential that the correct nose equipment is fitted to the tool to ensure both effective placing of the fastener and SAFE operation of the tool. READ THE SAFETY INSTRUCTIONS in the 7536 tool manual carefully.



Fitting a Nose Jaw

Loading the Tool

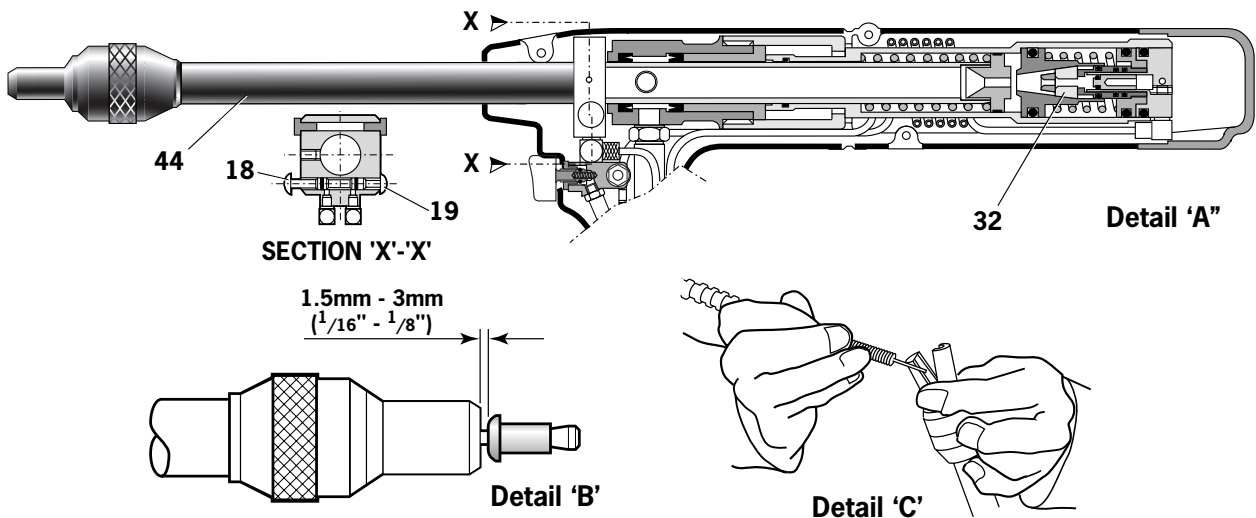
- Connect the air supply to the tool.
- Open Tail Jaws **32** (Detail 'A' below) which grip the mandrel, by switching off the tail jaw switch (items **18** and **19** on Detail 'A' below).
- Screw selected nose jaws onto Barrel **44** (Detail 'A' below) of the tool.
- Insert a mandrel into the tail end of the fasteners through the paper pod.
- Slide the mandrel follower spring onto the mandrel ensuring correct orientation, as shown in the table on page 2.
- Gripping the tail end of the mandrel, tear off the paper pod from around the fasteners.
- Open the nose jaws either by rotating the outer ring on Cam operated jaws or by pushing outwards on the jaw ends, as illustrated Detail 'C' below.
- Insert the previously assembled mandrel, mandrel follower spring and fasteners into the nose jaws until the first fastener to be placed is protruding from the nose jaw.
- Close the nose jaws and adjust so that the first fastener protrudes by 1.5mm - 3mm ($1/16''$ to $1/8''$), as shown in the illustration Detail 'B' below.
- Close the Tail Jaws **32** to ensure the mandrel is gripped, by switching on the tail jaw switch (items **18** and **19**).

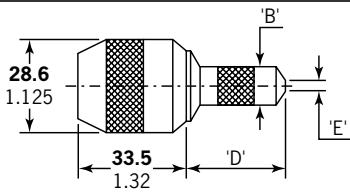
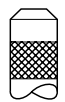
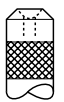
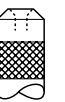

Selecting a Nose Jaw

STANDARD	FLAT	UNIVERSAL	RECESSED	TAPERED
				
Dimensions shown in bold are in millimetres. Other dimensions are in inches.				

Nose Jaw Selection - Imperial

FASTENER	REFERENCE NUMBER	TYPE AND END FORM	PART NUMBER	NOSE JAW DIMENSIONS		
				'B'	'D'	'E'
$1/16''$ AVLUG [®]	27-1	LIMITED ACCESS	07154-03102	0.22	0.99	0.11

Nose Jaw Selection - Metric

FASTENER	REFERENCE NUMBER	TYPE AND END FORM	PART NUMBER	NOSE JAW DIMENSIONS		
				'B'	'D'	'E'
$1/16''$ AVLUG [®]	27-1	LIMITED ACCESS	07154-03102	5.59	25.15	2.79

Use of Mandrels

Mandrels and mandrel follower springs need to be selected to suit the fastener type and size as well as the size of the hole in the application. Use of the wrong mandrel could increase the risk of breakage and the wear of the mandrel head. Feeding problems could occur if the wrong mandrel follower spring is used.

I M P O R T A N T

READ THE SAFETY INSTRUCTIONS in the 7536 tool manual carefully. While a small amount of wear and marking will naturally occur through normal and correct use of mandrels, they must be regularly examined for excessive wear and marking, with particular attention to the head diameter, the tail jaw gripping area of the shank or heavy pitting of the shank and any mandrel distortion. Mandrels which fail during use could forcibly exit the tool. It is the customer's responsibility to ensure that mandrels are replaced before any excessive levels of wear and always before the maximum recommended number of placings. Contact your Avdel representative who will let you know what that figure is by measuring the broach load of your application with our calibrated measuring tool. These tools can also be purchased under part number 07900-09080, supplied with all necessary information for testing.

Mandrel Head Types and 'P' Length

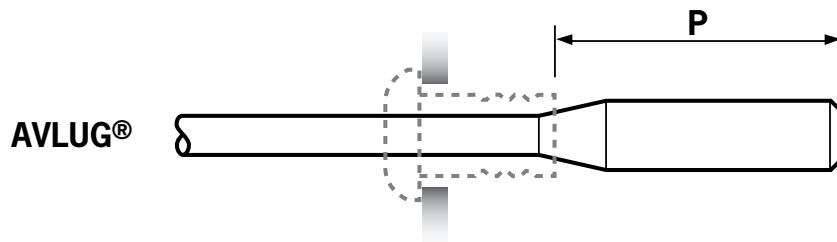

FASTENER	REFERENCE NUMBER	HOLE SIZE	STANDARD MANDREL- GREEN			HOLE SIZE	1st OVERSIZE MANDREL- YELLOW			SPRING PART NUMBER
			HEAD	MANDREL PART NUMBER	'P' MAXIMUM		HEAD	MANDREL PART NUMBER	'P' MAXIMUM	
1/16" AVLUG [®]	27-1	AS REC	0.515	07154-06602	0.335	+0.005	0.565	07155-06702	0.381	07154-06802

FASTENER	REFERENCE NUMBER	HOLE SIZE	STANDARD MANDREL- GREEN			HOLE SIZE	1st OVERSIZE MANDREL- YELLOW			SPRING PART NUMBER
			HEAD	MANDREL PART NUMBER	'P' MAXIMUM		HEAD	MANDREL PART NUMBER	'P' MAXIMUM	
1/16" AVLUG [®]	27-1	AS REC	1.31	07154-06602	9.02	+0.10	1.44	07155-06702	9.68	07154-06802



Since 1922

**Avdel® iForm™**

Since 1936

2010



Our Technology, Your Success

AUSTRALIA**Infastech (Australia) Pty Ltd.**

891 Wellington Road
Rowville
Victoria 3178
Tel: +61 3 9765 6400
Fax: +61 3 9765 6445
info@infastech.com.au

CANADA**Avdel Canada Limited**

1030 Lorimar Drive
Mississauga
Ontario L5S 1R8
Tel: +1 905 364 0664
Fax: +1 905 364 0678
infoAvdel-Canada@infastech.com

CHINA**Infastech (China) Ltd.**

RM 1708, 17/F., Nanyang Plaza,
57 Hung To Rd., Kwun Tong
Hong Kong
Tel: +852 2950 0631
Fax: +852 2950 0022
infochina@infastech.com

FRANCE**Avdel France S.A.S.**

33 bis, rue des Ardennes
BP4
75921 Paris Cedex 19
Tel: +33 (0) 1 4040 8000
Fax: +33 (0) 1 4208 2450
AvdelFrance@infastech.com

GERMANY**Avdel Deutschland GmbH**

Klusriede 24
30851 Langenhagen
Tel: +49 (0) 511 7288 0
Fax: +49 (0) 511 7288 133
AvdelDeutschland@infastech.com

INDIA**Infastech Fastening Technologies****India Private Limited**

Plot No OZ-14, Hi Tech SEZ,
SIPCOT Industrial Growth Center,
Oragadam, Sriperumbudur Taluk,
Kanchipuram District,
602105 Tamilnadu
Tel: +91 44 4711 8001
Fax: +91 44 4711 8009
info-in@infastech.com

ITALY**Avdel Italia S.r.l.**

Viale Lombardia 51/53
20047 Brugherio (MI)
Tel: +39 039 289911
Fax: +39 039 2873079
vendite@infastech.com

JAPAN**Infastech Kabushiki Kaisha**

Center Minami SKY,
3-1 Chigasaki-Chuo, Tsuzuki-ku,
Yokohama-city,
Kanagawa Prefecture
Japan 224-0032
Tel: +81 45 947 1200
Fax: +81 45 947 1205
info@infastech.co.jp

MALAYSIA**Infastech (Malaysia) Sdn Bhd**

Lot 63, Persiaran Bunga Tanjung 1,
Senawang Industrial Park
70400 Seremban
Negeri Sembilan
Tel: +606 676 7168
Fax: +606 676 7101
info-my@infastech.com

SINGAPORE**Infastech (Singapore) Pte Ltd.**

31 Kaki Bukit Road 3
#05-03/06 Techlink
Singapore, 417818
Tel: +65 6372 5653
Fax: +65 6744 5643
info-sg@infastech.com

SOUTH KOREA**Infastech (Korea) Ltd.**

212-4, Suyang-Ri,
Silchon-Eup, Kwangju-City,
Kyunggi-Do, Korea, 464-874
Tel: +82 31 798 6340
Fax: +82 31 798 6342
info@infastech.co.kr

SPAIN**Avdel Spain S.A.**

C/ Puerto de la Morcuera, 14
Poligono Industrial Prado Overa
Ctra. de Toledo, km 7,8
28919 Leganés (Madrid)
Tel: +34 91 3416767
Fax: +34 91 3416740
ventas@infastech.com

TAIWAN**Infastech/Tri-Star Limited**

No 269-7, Baodong Rd,
Guanmiao Township,
71841 Tainan County,
Taiwan, R.O.C
Tel: +886 6 596 5798 (ext 201)
Fax: +886 6 596 5758
info-tw@infastech.com

UNITED KINGDOM**Avdel UK Limited**

Pacific House
2 Swiftfields
Watchmead Industrial Estate
Welwyn Garden City
Hertfordshire AL7 1LY
Tel: +44 (0) 1707 292000
Fax: +44 (0) 1707 292199
enquiries@infastech.com

USA**Avdel USA LLC**

614 NC Highway 200 South
Stanfield, North Carolina 28163
Tel: +1 704 888 7100
Fax: +1 704 888 0258
infoAvdel-USA@infastech.com

Data Sheet No.	Issue	Change Note No.
07900-00863	A	06/094
	B	07/044
	B2	07/103
	B3	11/082

www.avdel-global.com
www.infastech.com

Autosert® (equipment), Avbolt®, Avdel®, Avdelmate®, Avdel TX2000®, Avdelok®, Avex®, Avibulb®, Avinox®, Avinut™, Avlug®, Avmatic®, Avplas®, Avseal®, Avsert®, Avtainer®, Avtronic®, Briv®, Bulbex®, Chobert®, Eurosert®, Fastriv®, Finsert®, Genesis®, Grovit®, Hemlok®, Hexsert®, Holding your world together®, Hydra®, Interlock®, Klamp-Tite®, KlampTite KTR®, Kvex®, Maxlok®, Monobolt®, Monobulb®, Neobolt®, Nutsert®, Nutsert SQ®, Portariv®, Rivmatic®, Rivscrew®, Speed Fastening®, Squaresert®, Stavex®, Supersert®, Thin Sheet Nutsert®, Titan®, T-Lok®, TLR®, TSN®, TX2000®, Versa-Nut®, Viking® and Viking 360® are trademarks of Avdel UK Limited. Infastech™ and Our Technology, Your Success™ are trademarks of Infastech Intellectual Properties Pte Ltd. The names and logos of other companies mentioned herein may be trademarks of their respective owners. This document is for informational purposes only. Infastech makes no warranties, expressed or implied, in this document. Data shown is subject to change without prior notice as a result of continuous product development and improvement policy. Your local Avdel representative is at your disposal should you need to confirm latest information.