



Instruction Manual

Original Instruction



TX2000

Battery Powered Tool

Contents

Safety Rules	4
Specifications	5
Intent of Use	
Tool Capability & Nose Tips	6
Fastener Placing Matrix & Nose Tips	7
Before Starting	
Charging Procedure	8-9
Battery Handling	9
Nose Equipment	10
Operating Procedure	11
Changing Nose Equipment	12
Servicing the Tool	
Daily/Weekly/Annually	13
Parts List	13
Priming Procedure	14-15
Troubleshooting	16
Safety Data	
Grease and oil	17

LIMITED WARRANTY

Avdel makes the limited warranty that its products will be free of defects in workmanship and materials which occur under normal operating conditions. This Limited Warranty is contingent upon: (1) the product being installed, maintained and operated in accordance with product literature and instructions, and (2) confirmation by Avdel of such defect, upon inspection and testing. Avdel makes the foregoing limited warranty for a period of twelve (12) months following Avdel's delivery of the product to the direct purchaser from Avdel. In the event of any breach of the foregoing warranty, the sole remedy shall be to return the defective Goods for replacement or refund for the purchase price at Avdel's option. THE FOREGOING EXPRESS LIMITED WARRANTY AND REMEDY ARE EXCLUSIVE AND ARE IN LIEU OF ALL OTHER WARRANTIES AND REMEDIES. ANY IMPLIED WARRANTY AS TO QUALITY, FITNESS FOR PURPOSE, OR MERCHANTABILITY ARE HEREBY SPECIFICALLY DISCLAIMED AND EXCLUDED BY AVDEL.

Avdel UK Limited policy is one of continuous product development and improvement and we reserve the right to change the specification of any product without prior notice.

Safety Rules

This instruction manual must be read with particular attention to the following safety rules, by any person installing, operating, or servicing this tool.

- 1** Do not use outside the design intent.
- 2** Do not use equipment with this tool other than that recommended and supplied by Avdel UK Limited.
- 3** Any modification undertaken by the customer to the tool, nose assemblies, accessories or any equipment supplied by Avdel UK Limited or their representatives, shall be the customer's entire responsibility. Avdel UK Limited will be pleased to advise upon any proposed modification.
- 4** The tool must be maintained in a safe working condition at all times. The operator must follow the Daily and Weekly service checks as detailed on page 13.
- 5** The tool shall at all times be operated in accordance with relevant Health and Safety legislation. In the U.K. the "Health and Safety at Work etc. Act 1974" applies. Any question regarding the correct operation of the tool and operator safety should be directed to Avdel UK Limited or an authorised representative.
- 6** The precautions to be observed when using this tool must be explained by the customer to all operators.
- 7** Do not operate a tool that is directed towards any person(s) or the operator.
- 8** Always adopt a firm footing or a stable position before operating the tool.
- 9** Ensure that vent holes do not become blocked or covered.
- 10** Do not operate the tool if it is not fitted with a complete nose assembly.
- 11** The stem collector must be emptied when half full.
- 12** When using the tool, the wearing of safety glasses is required both by the operator and others in the vicinity to protect against fastener ejection, should a fastener be placed 'in air'. We recommend wearing gloves if there are sharp edges or corners on the application.
- 13** Care shall be taken to ensure that spent stems are not allowed to create a hazard.
- 14** Take care to avoid entanglement of loose clothes, ties, long hair, cleaning rags etc. in the moving parts of the tool which should be kept dry and clean for best possible grip.
- 15** When carrying the tool from place to place keep hands away from the trigger to avoid inadvertent start up.
- 16** Excessive contact with hydraulic fluid oil should be avoided. To minimize the possibility of rashes, care should be taken to wash thoroughly.
- 17** Do not operate the tool or the charger in an environment allowing exposure to moisture, rain, combustible fluids or gasses.
- 18** Regularly check the plug, cord and charger and in case of damage have repairs completed by an authorised Avdel representative.
- 19** Remove the battery when not in use, or before servicing / repairing the tool.
- 20** Do not discard batteries into water or fire, (danger of explosion). The battery must be disposed of in accordance with environmental regulations.
- 21** C.O.S.H.H. data for all hydraulic oils and lubricants is available on request from your tool supplier.

Specifications

Tool Specification

Stroke	Minimum - Maximum	22.0 mm (0.866 in)
Pull Force	Minimum	11.0 kN (2444 lbf)
Operating Voltage		12V DC
Cycle time	Approx. @ Full Stroke	2.0 seconds
Noise Level		70 dB(A)
Vibration	Less than	2.5 m/s ² (8 ft/s ²)
Weight	With nose equipment	2.5 kg (5.51 lb)

The tool will be supplied with either of the two charger types listed below. To identify the correct type, please refer to the specification number on the charger label.

Charger Specification AP-HBW/tu 1203

Input Supply	UK/Europe/Australia	220/240 V (50 Hz)
	USA/Canada/Japan	110V (60 Hz)
Output Supply		12 V (3A)
Charging Time	12 V/2.0 Ah battery	40 minutes
Intelligent Charger	Charges according to remaining battery charge	
Battery Type	Suitable for cell chemistry Ni-Cd and Ni-MH	
Weight		0.440 kg (0.97 lb)

Charger Specification AP-ULE-1201 & AP/ULUJ-1201

Charger Type	AP/ULE-1201 and AP/ULUJ-1201		
Input Supply	UK/European/Australian Specification	220-240 V	50-60 Hz
	USA/Canada/Japan Specification	100-110V	50-60 Hz
Output Supply		12 V	3A
Charging Time	12 V/2.0 Ah Ni-Cd battery (90% Capacity)	40 minutes	
	12 V/2.0 Ah Ni-Cd battery (100% Capacity)	50 minutes	
Advanced Intelligent Charger	Patented design. Charges according to remaining battery capacity with automatic trickle charge to achieve optimum battery capacity		
Battery Type	Suitable for charging both Ni-Cd and Ni-MH cell chemistry with a capacity of 1.2Ah-3.0Ah.		
Weight		0.5 kg	1.1 lb

Battery Specification

Output Voltage	12V DC
Capacity	2.0 Ah
Number of Cells	10
Cell Construction	Ni-Cd (with NTC thermal overcharge protection)
Weight	0.65 kg (1.43 lb)

Intent of Use

The TX2000 is a battery powered hydraulic tool designed for placing Avdel® breakstem fasteners from 3.0mm to 6.4mm (1/4") as shown in the table below and detailed on page 7.

IMPORTANT: The tool, battery and charger must be used in accordance with the operating instructions and safety rules contained within this manual. The placing of other fastener sizes or materials not included in the table on page 7 could have a detrimental impact on the working life of the tool and could invalidate the warranty. The tool should only be dismantled by a Avdel authorised distributor or repair centre. Failure to do so could invalidate the warranty.

Standard Tool Kit

The standard tool kit consists of:

- A battery powered hydraulic tool
- A nose assembly and three nose tips
- A battery and charger
- A priming pump
- An Instruction Manual

These are housed in a durable storage case.

Standard Nose Tips

The three nose tips and nose assembly supplied as standard with the tool make up a nose assembly part kit (71210-15100). These nose tips will place the range of Avdel® breakstem fasteners summarised below.

Standard Nose Tip	Fastener Size	Fastener Material
71210-05002	3.0mm – 3.2mm (1/8")	Aluminium / Stainless Steel / Copper
71210-16070	3.2mm (1/8")	Steel / Stainless Steel
	4.0mm (5/32")	Aluminium / Stainless Steel / Copper
07381-04701	4.0mm (5/32")	Steel / Stainless Steel
	4.8mm (3/16")	Aluminium

Please refer to the matrix on page 7 for a full list of the fastener materials and sizes the TX2000 will place along with the nose tip part numbers required to place them.

Intent of Use

The matrix below shows the range of Avdel® breakstem fasteners the TX2000 will place along with the nose tip part numbers required.

Placing Matrix

Fastener Series	Description	Fastener Size						
		3.0mm	3.2mm (1/8")	4.0mm (5/32")	4.3mm	4.8mm (3/16")	6.4mm (1/4")	
Aluminium	Avex® 1601	Snap Head		71210-05002	71210-16070		07381-04701	
	Avex® 1604	120° Countersunk		07340-06401	07340-06501		07340-06601	
	Avex® 1641	Large Flange					07340-04800	
	Avex® 1661	Low Profile	71210-05002	71210-05002	71210-16070		07381-04701	
	Avex® 1663	Low Profile (St. Steel Stem)	71210-05002	71210-05002	71210-16070		07381-04701	
	Avex® 1691	Low Profile (Gold Pass. Stem)	71210-05002	71210-05002	71210-16070		07381-04701	
	Avex® 1695	Low Profile (Gold Pass. Stem)						07612-02001
	Avdel® MG91	Low Profile (Gold Pass. Stem)		71210-16030	71210-16033		71210-16036	
	Bulbex® BF01	Snap Head			71210-16070		07381-04701	
	SR Rivet SR01	Raised Head		71210-05002	71210-16070		07348-07001	71220-60001
	SR Rivet SR02	Raised Head (St. Steel Stem)		71210-05002	71210-16070		07348-07001	
	SR Rivet SR21	120° Countersunk		71210-05002	71210-16070		07348-07001	
	Monobolt® 2764	100° Countersunk					71210-16020	71220-16021
	Monobolt® 2774	Protruding Head					71210-16020	71220-16021
	Interlock BAP I	Protruding Head					07381-04701	07612-02001
	Hemlok® 2241	Protruding Head						71230-15800
TLR® 3904	Protruding Head					07605-00220	07498-01101	
Steel	Avex® 1610	Low Profile (Splined)			07381-04701		07490-04401	
	Avex® 1624	Low Profile		71210-16070	07381-04701		07490-04401	
	Avex® BX24	Low Profile (Blunt Stem)		71210-16070	07381-04701		07490-04401	
	Stavex® BS01	Low Profile		71210-05002	71210-16070		07381-04701	
	Stavex® BS04	120° Countersunk					07340-06601	
	Stavex® BS10	Low Profile					07381-04701	
	Stavex® BE34	Large Flange					07340-04800	
	Avibulb® BN01	Snap Head		71210-16070	07381-04701		07498-01401	
	T-Lok® BM01	Low Profile				07340-06201	07340-06201	
	Monobolt® 2761	100° Countersunk					71210-16020	
	Monobolt® 2771	Protruding Head					71210-16020	
	Interlock SSP I	Protruding Head					07381-04701	
	Interlock SSC I	Countersunk					07381-04701	
Stainless Steel	Stavex® BS11	Low Profile		71210-05002	71210-16070		07381-04701	
	Avinox® IBE11	Snap Head		71210-16070	07381-04701		07498-01401	
	Avinox® I BE61	Snap Head		71210-16070	07381-04701		07498-01401	
	SR Rivet SR41	Raised Head		71210-05002	71210-16070		07348-07001	
	Monobolt® 2711	Protruding Head					71210-16020	71220-16021
Copper	SR Rivet SR03	Raised Head		71210-05002	71210-16070		07348-07001	
	SR Rivet SR05	Raised Head (Copper-Nickel)			71210-16070		07348-07001	

Before Starting

Before starting, please read and follow the operating instructions carefully.

Charging Procedure AP-HBW/tu 1203

- The charger must only be used with Avdel® batteries.
- Take the charger out of the case and connect to the mains power supply. The solid red LED indicates that the charger is operational.
- Insert the battery correctly into the charger with minimal force.
- If the green LED flashes when the battery is inserted this indicates that the battery is too hot. Remove the battery and allow to cool before trying again.
- The battery charging process is indicated by a solid green LED.
- Re-charging takes up to 40 minutes, depending upon the level of charge remaining within the battery.
- The end of the charging process is indicated by the flashing green LED.

Charging Procedure AP/ULE-1201 & AP/ULUJ-1201

- The charger must only be used with Avdel® batteries.
- Take the charger out of the storage case and connect to the mains power supply. The Left LED will be SOLID RED. The Right LED will be SOLID GREEN for 2 seconds - in this time a self-test will be performed - indicating that the charger is operational.
- If the LH LED FLASHES RED this indicates that the charger is not functioning correctly - charging is not possible. If this occurs please contact an authorised Avdel representative.
- Insert the battery correctly into the charger with minimal force.
- The battery charging process is indicated by the SOLID GREEN RH LED.
- If the RH LED FLASHES RED when the battery is inserted this indicates that the battery is too hot. Remove the battery from the charger and allow it to cool before trying again. This will occur when the battery temperature is above 65°C and can result if the battery is inserted directly after charging or discharging.
- If the RH LED shows SOLID RED this indicates that the battery is faulty. Remove battery from the charger and do not use.
- A SOLID YELLOW RH LED indicates that the battery is at least 90% charged. Removing the battery at this point will increase the service life of the battery. No significant reduction in the performance of the battery will result.
- A FLASHING GREEN RH LED indicates that the charging process is complete. The battery will now be at 100% capacity. At this point the battery will be trickle charged until removed. Overcharging of the battery will not occur.
- When charging a Ni-MH battery the RH LED can be seen to FLASH RED & GREEN. This also indicates that the charging process is complete.

Before Starting

A summary of the charger LED signals are shown in the table below:

1. LEFT LED		2. RIGHT LED	
Solid Red LED:	Charger Operational	Solid Green LED:	Charging In Progress
Flashing Red LED:	Charger Faulty - Do not use	Solid Yellow LED:	Battery At Least 90% Charged
		Flashing Green LED:	Charging Process Complete - 100% Charged
		Flashing Red & Green LED:	Charging Process Complete - Ni-MH
		Solid Red LED:	Battery Faulty Or Damaged - Do Not Use
		Flashing Red LED:	Battery Too Hot Or Cold

To achieve the optimum performance from the battery, please adhere to the following guidelines when charging:

- Aim to charge when both the battery and charger are cool. Optimum charge capacity is achieved when charging a battery at 28°C.
- A new battery will only reach full capacity after several charges.
- To increase the service life of the battery, remove from the charger when the RH LED shows solid yellow.
- To increase the service life of the battery, only re-charge when no further fasteners can be placed.
- To achieve the maximum number of cycles from a battery use directly after charging.

Battery Handling & Disposal

- Batteries must only be charged using the Avdel® charger supplied.
- Only re-charge batteries when cool. Optimum charge capacity is achieved at 28°C.
- The battery can be charged up to 1000 times. Optimum life is achieved when used at 22°C. The battery will reach its full capacity only after several charges.
- The surrounding temperature must not exceed 50°C (122°F) or be below -40°C (-40°F) for the battery to operate.
- For optimum life and performance only re-charge the battery when no further fasteners can be placed.
- For optimum performance use the battery directly after re-charging.
- Significantly reduced operating time of the battery after a complete re-charge indicates that the battery needs replacing.
- Store the battery in a frost free and dry environment.
- To ensure that the batteries are disposed of correctly please return to an authorized recycling centre.
- Used batteries must not get into waste, fire or water under any circumstance.

Before Starting

Nose Equipment

- A complete tool includes the nose assembly kit 71210-15100 with the following three nose tips as standard: 71210-05002, 71210-16070 and 07381-04701 (Please refer to page 7 for details of the range of fasteners they will place). Nose tip 07381-04701 is supplied fitted to the nose assembly and the other two are screwed into the front end of the tool.
- It is important that you check that the nose tip already fitted to the nose assembly is the correct one to place your fastener by sliding the fastener stem into the nose tip. No force should be required and play should be minimal.
- To change nose equipment, please refer to the instructions and list of components on page 12.

Operating Procedure

- Connect the charged battery to the tool.
- Insert the fastener stem into the nose of the tool. If using a standard nose tip the fastener must be held manually until placed into the application.
- Bring the tool with the fastener to the application so that the protruding fastener enters the hole of the application squarely.
- Fully actuate the trigger. The tool will cycle and place the fastener. Release the trigger only when the fastener stem has broken, the piston will then return to the forward position.
- After each cycle, the spent fastener stem must be disposed of by tilting the tool nose up, allowing the stem to fall back into the collection container at the rear of the tool.
- If the trigger is not released the tool will stop after approximately 4 seconds of operation, preventing overload. Releasing the trigger will reset the control circuit allowing the tool to operate as before.
- Empty the collection container when more than half full of stems.
- To empty the collection container tilt the tool nose down and lift the collector lid.
- Please read daily servicing details on page 13.

To achieve the optimum performance from the tool, please adhere to the following guidelines when operating:

- Fully depress the trigger when placing fasteners to achieve the optimum cycle rate, pull-force and efficiency.
- Release the trigger immediately after the rivet stem has broken in order to gain the maximum number of cycles from the battery.
- Do not operate the tool to the point of pressure relief and motor cut-out. These features are only to protect the tool from operator overload and abuse. Continual operation in this way will rapidly drain the battery.

Changing Nose Equipment

IMPORTANT: The battery must be disconnected when fitting or removing the nose assemblies.

Item **numbers in bold** refer to nose assembly components illustrated below.

- Remove items in reverse order to that shown below
- Lightly coat jaws **4** with Moly-lithium grease.
- Drop jaws **4** into jaw housing **3**.
- Insert jaw spreader **5** into the jaw housing **3**.
- Locate buffer **6** on the jaw spreader **5**.
- Locate spring **7** onto jaw spreader **5**.
- Fit locking ring **8** onto the jaw spreader housing of the tool.
- Holding the tool pointing down, screw the assembled jaw housing onto the jaw spreader housing and tighten with spanner.
- Screw the nose tip into nose casing **1** and tighten with nose tip spanner. Nose tip spanner 71600-02024 included with the tool will fit the three nose tips supplied with the tool as standard.
- Place nose casing **1** over jaw housing **3** and screw onto the tool, tighten with spanner.

NOSE ASSEMBLY		
part n° 71210-15000		
(+ 3 nose tips above = 71210-15100)		
ITEM	DESCRIPTION	PART N°
1	NOSE CASING	07340-00306
2	'O' RING	07003-00067
3	JAW HOUSING	07340-00304
4	JAWS	71210-15001
5	JAW SPREADER	07498-04502
6	BUFFER	71210-05001
7	SPRING	07498-04301
8	LOCKING RING	07340-00327

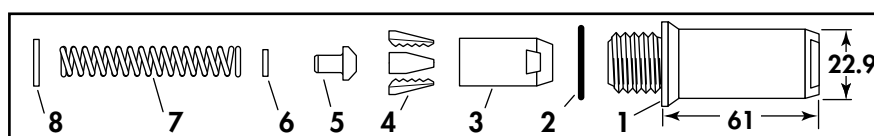

Servicing the Tool

IMPORTANT: The employer is responsible for ensuring that tool maintenance instructions are given to the appropriate personnel. The operator should not be involved in maintenance or repair of the tool unless properly trained. The tool must be examined regularly for damage and malfunction.

The following service checks should be performed:

Daily

- Check for oil leaks*.
- Check that the nose assembly is correct for the fastener to be placed. Please refer to page 7.

Weekly

- Check for oil leaks*.
- Dismantle and clean the nose assembly with special attention to the jaws using the following procedures:
 - Remove the nose equipment using the reverse procedure to the instructions for changing nose equipment on page 12.
 - Any worn or damaged part should be replaced.
 - Clean and check wear on jaws.
 - Ensure that the jaw spreader is not distorted.
 - Check spring **7** is not distorted.
 - Assemble according to the fitting instructions on page 12.

Annually

(or every 500,000 cycles, whichever is the soonest)

Please return your tool to your local Avdel® authorised distributor or repair centre.

Parts List

please refer to page 7 for nose tip part numbers

Part No.	Description
07007-01954	Battery (Ni-Cd 12V/2.0 Ah)
07007-01977	Battery (Ni-MH 12V/2.2 Ah)
71600-02024	Nose tip spanner
07007-01965	Battery charger: 220/240V~50Hz (UK)
07007-01966	Battery charger: 220/240V~50Hz (Europe)
07007-01967	Battery charger: 220/240V~50Hz (Australia)
07007-01968	Battery charger: 110V~60Hz (USA/Canada)
07007-01969	Battery charger: 100V~50/60Hz (Japan)
07007-01960	Storage case
07900-00759	Tool Instruction Manual - UK version
07992-00020	Moly-lithium grease
07992-00076	Hyspin® AWS 15 oil (0.5 litre)
07992-00077	Hyspin® AWS 15 oil (1 gallon)
07900-00754	Priming pump

* please refer to page 17 for relevant safety data

Priming Procedure

Priming may be necessary after considerable use.

Oil Details

The recommended oil for priming is Hyspin® AWS 15 available in 0.5 litre (part number 07992-00076) or one gallon containers (part number 07992-00077). Please refer to page 17 for safety data.

Procedure

To enable you to follow the priming procedure below, you will need to obtain a priming kit:

PRIMING KIT : 07900-00789	
PART N°	DESCRIPTION
07900-00754	PRIMING PUMP
07992-00076	OIL - 0.5 LITRE HYSPIN® AWS 15
07900-00351	3mm ALLEN KEY

IMPORTANT: REMOVE NOSE ASSEMBLY

All operations should be carried out on a clean bench, with clean hands in a clean area.

Ensure that the oil is perfectly clean and free from air bubbles.

Care MUST be taken at all times, to ensure that no foreign matter enters the tool, or serious damage may result.

- Remove the nose casing from the tool following the instructions on page 12, in reverse order.
- Remove screws and seals from cylinder bleed point, **position 1**, and reservoir inlet point, **position 2**, as illustrated on page 15.
- Invert the tool over a suitable container and actuate the trigger with the battery connected. Waste oil will be ejected through the bleed screw hole in the cylinder, **position 1**.
- Replace screw and seal in the cylinder, **position 1** only.
- Hold the tool nose up in a vice using soft jaws to avoid damage. DO NOT USE UNDUE FORCE WHEN CLAMPING THE VICE ON THE TOOL.
- Completely fill the priming pump 07900-00754 with oil.
- Screw the priming pump 07900-00754 into the reservoir inlet point, **position 2** with the seal in place.
- Gently pump the bellows on the priming pump repeatedly, inserting oil into the tool and allowing air to be collected in the priming pump. Continue this process until no further air bubbles are removed from the tool. The reservoir should now be full of oil. (Please refer to the diagram on page 15, **position 2**.)
- With the battery connected, actuate the trigger and gently compress the priming pump until the piston begins to move. Oil will then be drawn into the tool.
- Release the trigger and priming pump allowing the pump bellows to expand and suck air from the tool. Air bubbles will be visibly expelled from the reservoir inlet point, **position 2**, into the priming pump.
- Actuate the trigger and cycle the tool until the piston reaches full stroke. Release the trigger allowing the piston to return and air bubbles to be expelled into the priming pump. Repeat this procedure until no further air bubbles are expelled into the priming pump. Allow several seconds between each cycle so that the air bubbles have time to collect in the priming pump.
- Remove the priming pump from the reservoir inlet point, **position 2**, taking care not to spill excess oil over the tool.
- Top up the reservoir, **position 2**, to ensure that the tool is completely filled with oil.
- Replace screw and seal in the reservoir, inlet point, **position 2**.
- Replace the nose casing.

Priming Diagram

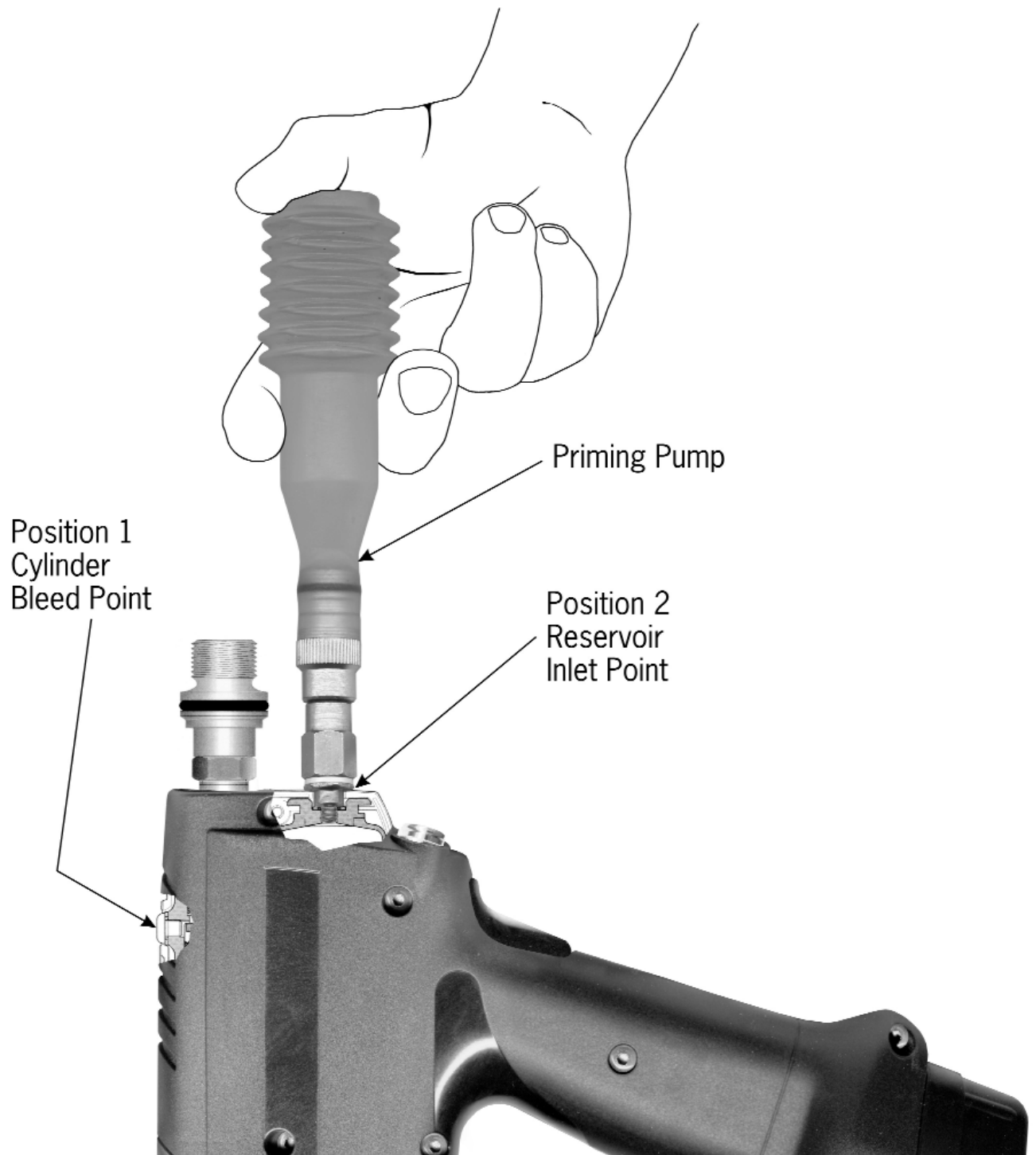

Fault Diagnosis

Symptom	Possible Cause	Remedy	Page Ref
More than one operation of the trigger needed to place fastener	Low battery charge	Charge or if necessary replace battery	8-9
	Worn or broken jaws	Fit new jaws	12
	Low oil level or air present in oil	Prime tool	14-15
	Build up of dirt inside nose assembly	Service nose assembly	13
Fastener fails to break	Fastener outside tool capability	Contact Avdel UK Limited	
	Low battery charge	Charge or if necessary replace battery	8-9
	Low oil level or air present in oil	Prime tool	14-15
Slow cycle	Low battery charge	Charge or if necessary replace battery	8-9
	Low oil level or air present in oil	Prime tool	14-15
	Build up of dirt inside nose assembly	Service nose assembly	13
Tool will not grip stem of fastener	Worn or broken jaws	Fit new jaws	12
	Build up of dirt inside nose assembly	Service nose assembly	13
	Loose jaw housing	Tighten against locking ring	12
	Weak or broken spring in nose assembly	Fit new spring	12
	Incorrect component in nose assembly	Identify and replace	12
Jaws will not release broken stem of fastener	Build up of dirt inside nose assembly	Service nose assembly	13
	Jaw housing, nose tip or nose casing not properly seated	Tighten nose assembly	12
	Weak or broken spring in nose assembly	Fit new spring	12
Cannot feed next fastener	Broken stems jammed inside tool	Empty stem collection container	13
		Check jaw spreader is correct	12
Tool fails to operate – motor operational	Low oil level or air present in oil	Prime tool	14-15
Tool fails to operate – motor not operational	Low battery charge	Charge or if necessary replace battery	8-9
	Battery not connected	Connect fully charged battery	8-9

Other symptoms or failures should be reported to your local Avdel UK authorised distributor or repair centre.

Safety Data (Grease and Oil)

MOLY-LITHIUM GREASE EP 3753 SAFETY DATA

First Aid

SKIN:

As the grease is completely water resistant it is best removed with an approved emulsifying skin cleaner.

INGESTION:

Ensure the individual drinks 30ml Milk of Magnesia, preferably in a cup of milk.

EYES:

Irritant but not harmful. Irrigate with water and seek medical attention.

Fire

FLASH POINT: Above 220°C.

Not classified as flammable.

Suitable extinguishing media: CO₂, Halon or water spray if applied by an experienced operator.

Environment

Scrape up for burning or disposal on approved site.

Handling

Use barrier cream or oil resistant gloves

Storage

Away from heat and oxidising agent.

HYSPIN® AWS 15 OIL SAFETY DATA

First Aid

SKIN:

Wash thoroughly with soap and water as soon as possible. Casual contact requires no immediate attention. Short term contact requires no immediate attention.

INGESTION:

Seek medical attention immediately. DO NOT induce vomiting.

EYES:

Irrigate immediately with water for several minutes. Although NOT a primary irritant, minor irritation may occur following contact.

Fire

Suitable extinguishing media: CO₂, dry powder, foam or water fog. DO NOT use water jets.

Environment

WASTE DISPOSAL: Through authorised contractor to a licensed site. May be incinerated. Unused product may be sent for reclamation.

SPILLAGE: Prevent entry into drains, sewers and water courses. Soak up with absorbent material.

Handling

Wear eye protection, impervious gloves (e.g. of PVC) and a plastic apron. Use in well ventilated area.

Storage

No special precautions.

These products can be ordered separately. Please refer to the parts list on page 13 for part numbers.

Notes

Declaration of Conformity

We, Avdel UK Limited, Watchmead Industrial Estate, Welwyn Garden City, Herts, AL7 1LY
declare under our sole responsibility that the product:

Model: TX2000

Serial No.

to which this declaration relates is in conformity with the following standards:

TX2000 Tool	Battery Charger
EN ISO 12100 - parts 1 & 2	VDE0700
EN 50260 - part 1	EN 60335-1
BS EN 982	EN 60335-2-29
BS EN ISO 8662 - part 6	EN 60742/0695
BS EN ISO 3744	EN 50081-1
ISO EN 792 part 13 - 2000	EN 55014
BS EN ISO 11202	EN 60555-2/3
BS EN 55014 part 1 & 2	EN 50082-1
BS EN 50081 part 1	EN 55104

following the provisions of the Machine Directive 2006/42/EC

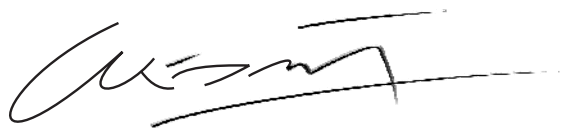

A. Seewraj - Product Engineering Manager - Automation Tools

Date of issue

 **This box contains a power tool which is in conformity with Machines Directive 2006/42/EC. The 'Declaration of Conformity' is contained within.**



Since 1922

**Avdel® iForm™**

Since 1936

2010



Our Technology, Your Success

AUSTRALIA**Infastech (Australia) Pty Ltd.**

891 Wellington Road
Rowville
Victoria 3178
Tel: +61 3 9765 6400
Fax: +61 3 9765 6445
info@infastech.com.au

CANADA**Avdel Canada Limited**

1030 Lorimar Drive
Mississauga
Ontario L5S 1R8
Tel: +1 905 364 0664
Fax: +1 905 364 0678
infoAvdel-Canada@infastech.com

CHINA**Infastech (China) Ltd.**

RM 1708, 17/F., Nanyang Plaza,
57 Hung To Rd., Kwun Tong
Hong Kong
Tel: +852 2950 0631
Fax: +852 2950 0022
infochina@infastech.com

FRANCE**Avdel France S.A.S.**

33 bis, rue des Ardennes
BP4
75921 Paris Cedex 19
Tel: +33 (0) 1 4040 8000
Fax: +33 (0) 1 4208 2450
AvdelFrance@infastech.com

GERMANY**Avdel Deutschland GmbH**

Klusriede 24
30851 Langenhagen
Tel: +49 (0) 511 7288 0
Fax: +49 (0) 511 7288 133
AvdelDeutschland@infastech.com

INDIA**Infastech Fastening Technologies****India Private Limited**

Plot No OZ-14, Hi Tech SEZ,
SIPCOT Industrial Growth Center,
Oragadam, Sriperumbudur Taluk,
Kanchipuram District,
602105 Tamilnadu
Tel: +91 44 4711 8001
Fax: +91 44 4711 8009
info-in@infastech.com

ITALY**Avdel Italia S.r.l.**

Viale Lombardia 51/53
20047 Brugherio (MI)
Tel: +39 039 289911
Fax: +39 039 2873079
vendite@infastech.com

JAPAN**Infastech Kabushiki Kaisha**

Center Minami SKY,
3-1 Chigasaki-Chuo, Tsuzuki-ku,
Yokohama-city,
Kanagawa Prefecture
Japan 224-0032
Tel: +81 45 947 1200
Fax: +81 45 947 1205
info@infastech.co.jp

MALAYSIA**Infastech (Malaysia) Sdn Bhd**

Lot 63, Persiaran Bunga Tanjung 1,
Senawang Industrial Park
70400 Seremban
Negeri Sembilan
Tel: +606 676 7168
Fax: +606 676 7101
info-my@infastech.com

SINGAPORE**Infastech (Singapore) Pte Ltd.**

31 Kaki Bukit Road 3
#05-03/06 Techlink
Singapore, 417818
Tel: +65 6372 5653
Fax: +65 6744 5643
info-sg@infastech.com

SOUTH KOREA**Infastech (Korea) Ltd.**

212-4, Suyang-Ri,
Silchon-Eup, Kwangju-City,
Kyunggi-Do, Korea, 464-874
Tel: +82 31 798 6340
Fax: +82 31 798 6342
info@infastech.co.kr

SPAIN**Avdel Spain S.A.**

C/ Puerto de la Morcuera, 14
Poligono Industrial Prado Overa
Ctra. de Toledo, km 7,8
28919 Leganés (Madrid)
Tel: +34 91 3416767
Fax: +34 91 3416740
ventas@infastech.com

TAIWAN**Infastech/Tri-Star Limited**

No 269-7, Baodong Rd,
Guanmiao Township,
71841 Tainan County,
Taiwan, R.O.C
Tel: +886 6 596 5798 (ext 201)
Fax: +886 6 596 5758
info-tw@infastech.com

UNITED KINGDOM**Avdel UK Limited**

Pacific House
2 Swiftfields
Watchmead Industrial Estate
Welwyn Garden City
Hertfordshire AL7 1LY
Tel: +44 (0) 1707 292000
Fax: +44 (0) 1707 292199
enquiries@infastech.com

USA**Avdel USA LLC**

614 NC Highway 200 South
Stanfield, North Carolina 28163
Tel: +1 704 888 7100
Fax: +1 704 888 0258
infoAvdel-USA@infastech.com

Manual No.	Issue	Change Note No.
07900-00759	AA	02/236
	B	07/044
	B2	07/142
	B3	11/081

www.avdel-global.com
www.infastech.com

Autosert® (equipment), Avbolt®, Avdel®, Avdelmate®, Avdel TX2000®, Avdelok®, Avex®, Avibulb®, Avinox®, Avinut™, Avlug®, Avmatic®, Avplas®, Avseal®, Avsert®, Avtainer®, Avtronic®, Briv®, Bulbex®, Chobert®, Eurosert®, Fastriv®, Finsert®, Genesis®, Grovit®, Hemlok®, Hexsert®, Holding your world together®, Hydra®, Interlock®, Klamp-Tite®, KlampTite KTR®, Kvex®, Maxlok®, Monobolt®, Monobulb®, Neobolt®, Nutsert®, Nutsert SQ®, Portariv®, Rivmatic®, Rivscrew®, Speed Fastening®, Squaresert®, Stavex®, Supersert®, Thin Sheet Nutsert®, Titan®, T-Lok®, TLR®, TSN®, TX2000®, Versa-Nut®, Viking® and Viking 360® are trademarks of Avdel UK Limited. Infastech™ and Our Technology, Your Success™ are trademarks of Infastech Intellectual Properties Pte Ltd. The names and logos of other companies mentioned herein may be trademarks of their respective owners. This document is for informational purposes only. Infastech makes no warranties, expressed or implied, in this document. Data shown is subject to change without prior notice as a result of continuous product development and improvement policy. Your local Avdel representative is at your disposal should you need to confirm latest information.