

## Genesis®

### Equipamento de Ponta de Desbloqueio Rápido

#### CONJUNTOS DE PONTA DE DESBLOQUEIO RÁPIDO:

71210-20310 - Conjunto com Garra 71210-15001  
(para tipos de ferramenta G2)

71220-20310 - Conjunto com Garra 71210-15001  
(para tipos de ferramenta G3/4)

71220-20350 - Conjunto com Garra 07612-02002  
(para tipos de ferramenta G3/4)

**Nota:** Consulte o Manual de instruções da ferramenta "Equipamento de Ponta" para o tipo de garra e o tipo de ponta adequado para o parafuso de fixação especificado.

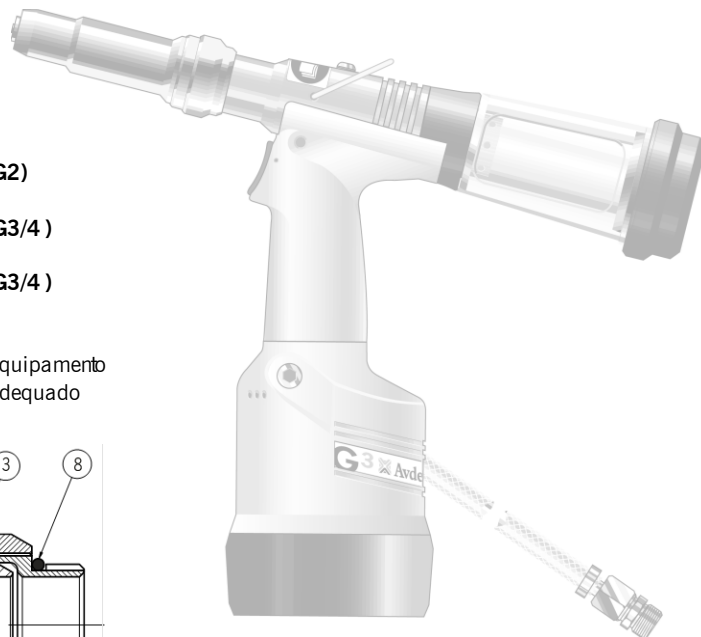
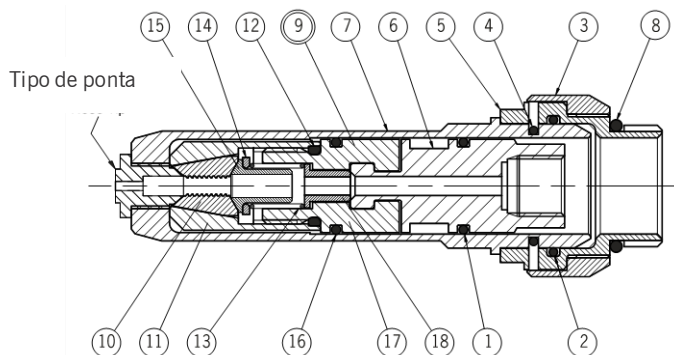

ARTIGO	DESCRIÇÃO	TIPO DE FERRAMENTA GENESIS®		
		nG1/nG2/nG2s G2/G2s/G2HD 71210-20310	nG3/nG4 G3/G4/G3HD/G4HD 71220-20310	nG3/nG4 G3/G4/G3HD/G4HD 71220-20350
1	"O" ring	07003-00277	07003-00369	07003-00369
2	"O" ring	07003-00342	07003-00368	07003-00368
3	Revestimento da mola	71210-20311	71220-20311	71220-20311
4	Mola "U"	71210-20312	71220-20312	71220-20312
5	Adaptador do invólucro de ponta	71210-20313	71220-20313	71220-20313
6	Adaptador "I"	71210-20314	71220-20314	71220-20314
7	Invólucro de ponta de desbloqueio rápido	71210-20316	71220-20316	71220-20316
8	"O" ring	07003-00349	07003-00349	07003-00349
9	*Cartucho do equipamento de ponta	71210-20320	71220-20320	71220-20360
10	Conjunto das garras	71210-15001	71210-15001	07612-02002
11	Alojamento de garras	07340-00304	07340-00304	07612-02003
12	Anel de bloqueio	07340-00327	07340-00327	07340-00327
13	Mola	07500-00418	07500-00418	07500-00418
14	Amortecedor	71210-05001	71210-05001	71210-05001
15	Alargador de garras	07498-04502	07498-04502	07498-04502
16	"O" ring	07003-00277	07003-00369	07003-00369
17	Alojamento "I" do alargador de garras	71210-20321	71220-20321	71220-20321
18	Manga de detenção	71210-20322	71220-20322	71220-20322

\*Artigos que constituem o cartucho do equipamento de ponta 10 ao 18

## Equipamento de Ponta de Desbloqueio Rápido Genesis®

### Para Preparar as Ferramentas Básicas para Aceitar Equipamento de Ponta de Desbloqueio Rápido

---

(Consulte o manual de instruções da ferramenta Genesis® relevante.)

- Para ferramentas nG3/4, G3/4 e G2/G2s retire o alojamento do alargador de garras 71210-02101.
- Para ferramentas nG1, nG2 e nG2s retire o adaptador "T" 71213-02020.
- Substitua a peça acima com o adaptador "T" (artigo 6). **Nota:** O adaptador "T" para ferramentas nG3/4 (artigo 6) é montado através do adaptador do invólucro de ponta Conjunto (artigos 2, 3, 4, 5 e 8).
- Aparafuse o conjunto do adaptador do invólucro de ponta (artigos 2, 3, 4, 5 e 8) à parte dianteira da ferramenta.
- O cartucho do equipamento de ponta (artigo 9) é montado no adaptador "T" (artigo 6) deslizando num plano normal ao do pistão.
- Empurre o invólucro de ponta de desbloqueio rápido (artigo 7) para o adaptador do invólucro de ponta (artigo 5) assegurando-se de que os planos estão alinhados, isto bloqueia o invólucro de ponta de desbloqueio rápido na posição.

### \*Para Remover o Equipamento de Ponta de Desbloqueio Rápido

---

- Rode 90 graus o invólucro de ponta de desbloqueio rápido (artigo 7) e puxe para fora o adaptador do invólucro de ponta (artigo 5).
- Para desbloquear o cartucho do equipamento de ponta (artigo 9) do adaptador "T" (artigo 6) deslize o cartucho num plano normal ao do pistão da cabeça.

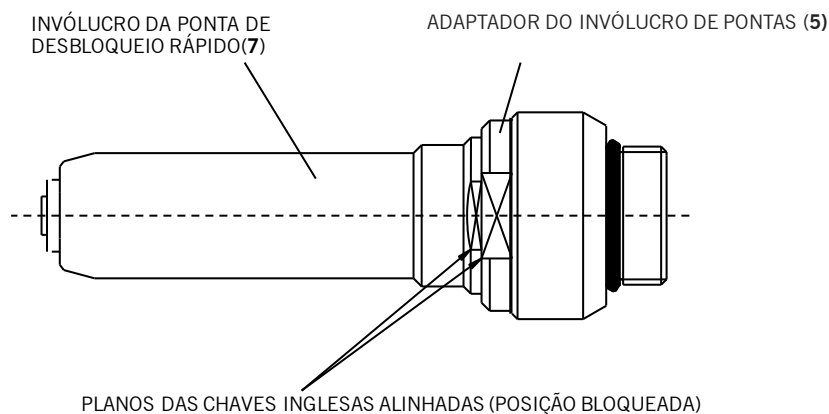

Referências de artigo a **negrito** consulte a lista de peças na página dianteira.



#### AUSTRÁLIA

##### Infastech (Australia) Pty Ltd.

891 Wellington Road  
 Rowville  
 Victoria 3178  
 Tel: +61 3 9765 6400  
 Fax: +61 3 9765 6445  
 info@infastech.com.au

#### CANADÁ

##### Avdel Canada Limited

1030 Lorimar Drive  
 Mississauga  
 Ontario L5S 1R8  
 Tel: +1 905 364 0664  
 Fax: +1 905 364 0678  
 infoAvdel-Canada@infastech.com

#### CHINA

##### Infastech (China) Ltd.

RM 1708, 17/F., Nanyang Plaza,  
 57 Hung To Rd., Kwun Tong  
 Hong Kong  
 Tel: +852 2950 0631  
 Fax: +852 2950 0022  
 infochina@infastech.com

#### FRANÇA

##### Avdel France S.A.S.

33 bis, rue des Ardennes  
 BP4  
 75921 Paris Cedex 19  
 Tel: +33 (0) 1 4040 8000  
 Fax: +33 (0) 1 4208 2450  
 AvdelFrance@infastech.com

#### ALEMANHA

##### Avdel Deutschland GmbH

Klusriede 24  
 30851 Langenhagen  
 Tel: +49 (0) 511 7288 0  
 Fax: +49 (0) 511 7288 133  
 AvdelDeutschland@infastech.com

#### ÍNDIA

##### Infastech Fastening Technologies

##### India Private Limited

Plot No OZ-14, Hi Tech SEZ,  
 SIPCOT Industrial Growth Center,  
 Oragadam, Sriperumbudur Taluk,  
 Kanchipuram District,  
 602105 Tamilnadu  
 Tel: +91 44 4711 8001  
 Fax: +91 44 4711 8009  
 info-in@infastech.com

#### ITÁLIA

##### Avdel Italia S.r.l.

Viale Lombardia 51/53  
 20047 Brugherio (MI)  
 Tel: +39 039 289911  
 Fax: +39 039 2873079  
 vendite@infastech.com

#### JAPÃO

##### Infastech Kabushiki Kaisha

Center Minami SKY,  
 3-1 Chigasaki-Chuo, Tsuzuki-ku,  
 Yokohama-city,  
 Kanagawa Prefecture  
 Japan 224-0032  
 Tel: +81 45 947 1200  
 Fax: +81 45 947 1205  
 info@infastech.co.jp

#### MALÁSIA

##### Infastech (Malaysia) Sdn Bhd

Lot 63, Persiaran Bunga Tanjung 1,  
 Senawang Industrial Park  
 70400 Seremban  
 Negeri Sembilan  
 Tel: +606 676 7168  
 Fax: +606 676 7101  
 info-my@infastech.com

#### SINGAPURA

##### Infastech (Singapore) Pte Ltd.

31 Kaki Bukit Road 3  
 #05-03/06 Techlink  
 Singapore, 417818  
 Tel: +65 6372 5653  
 Fax: +65 6744 5643  
 info-sg@infastech.com

#### REPÚBLICA DA COREIA

##### Infastech (Korea) Ltd.

212-4, Suyang-Ri,  
 Silchon-Eup, Kwangju-City,  
 Kyunggi-Do, Korea, 464-874  
 Tel: +82 31 798 6340  
 Fax: +82 31 798 6342  
 info@infastech.co.kr

#### ESPAÑA

##### Avdel Spain S.A.

C/ Puerto de la Morcuera, 14  
 Poligono Industrial Prado Overa  
 Ctra. de Toledo, km 7,8  
 28919 Leganés (Madrid)  
 Tel: +34 91 3416767  
 Fax: +34 91 3416740  
 ventas@infastech.com

#### TAIWAN

##### Infastech/Tri-Star Limited

No 269-7, Baodong Rd,  
 Guanmiao Township,  
 71841 Tainan County,  
 Taiwan, R.O.C  
 Tel: +886 6 596 5798 (ext 201)  
 Fax: +886 6 596 5758  
 info-tw@infastech.com

#### REINO UNIDO

##### Avdel UK Limited

Pacific House  
 2 Swiftfields  
 Watchmead Industrial Estate  
 Welwyn Garden City  
 Hertfordshire AL7 1LY  
 Tel: +44 (0) 1707 292000  
 Fax: +44 (0) 1707 292199  
 enquiries@infastech.com

#### EUA

##### Avdel USA LLC

614 NC Highway 200 South  
 Stanfield, North Carolina 28163  
 Tel: +1 704 888 7100  
 Fax: +1 704 888 0258  
 infoAvdel-USA@infastech.com

Manual No.	Issue	Change Note No.
07900-00798	A	07/044
	A2	07/103
	B	11/019

[www.avdel-global.com](http://www.avdel-global.com)  
[www.infastech.com](http://www.infastech.com)

Autosert® (equipment), Avbolt®, Avdel®, Avdelmate®, Avdel TX2000®, Avdelok®, Avex®, Avibulb®, Avinox®, Avinut™, Avlug®, Avmatic®, Avplas®, Avseal®, Avsert®, Avtainer®, Avtronic®, Briv®, Bulbex®, Chobert®, Eurosert®, Fastriv®, Finsert®, Genesis®, Grovit®, Hemlok®, Hexsert®, Holding your world together®, Hydra®, Interlock®, Klamp-Tite®, KlampTite KTR®, Kvex®, Maxlok®, Monobolt®, Monobulb®, Neobolt®, Nutsert®, Nutsert SQ®, Portariv®, Rivmatic®, Rivscrew®, Speed Fastening®, Squaresert®, Stavex®, Supersert®, Thin Sheet Nutsert®, Titan®, T-Lok®, TLR®, TSN®, TX2000®, Versa-Nut®, Viking® e Viking 360® são marcas comerciais da Avdel UK Limited. Infastech™ e Our Technology, Your Success™ são marcas comerciais da Infastech Intellectual Properties Pte Ltd. Os nomes e logótipos de outras empresas mencionadas neste documento podem ser marcas comerciais dos seus respectivos proprietários. Este documento tem objectivos meramente informativos. A Infastech não oferece quaisquer garantias, explícitas ou implícitas, neste documento. Os dados apresentados estão sujeitos a alterações sem aviso prévio em virtude do desenvolvimento contínuo do produto e do melhoramento da política. O seu representante local Avdel está à sua disposição caso precise de confirmar esta última informação.

# Genesis®

## Quick Release Nose Equipment

### QUICK RELEASE NOSE ASSEMBLIES:

71210-20310 - Assembly incorporating 71210-15001 Jaw  
(for G2 tool types)

71220-20310 - Assembly incorporating 71210-15001 Jaw  
(for G3/4 tool types)

71220-20350 - Assembly incorporating 07612-02002 Jaw  
(for G3/4 tool types)

**Note:** Refer to tool Instruction Manual 'Nose Equipment' for Jaw type and appropriate Nose Tip for specified fastener.

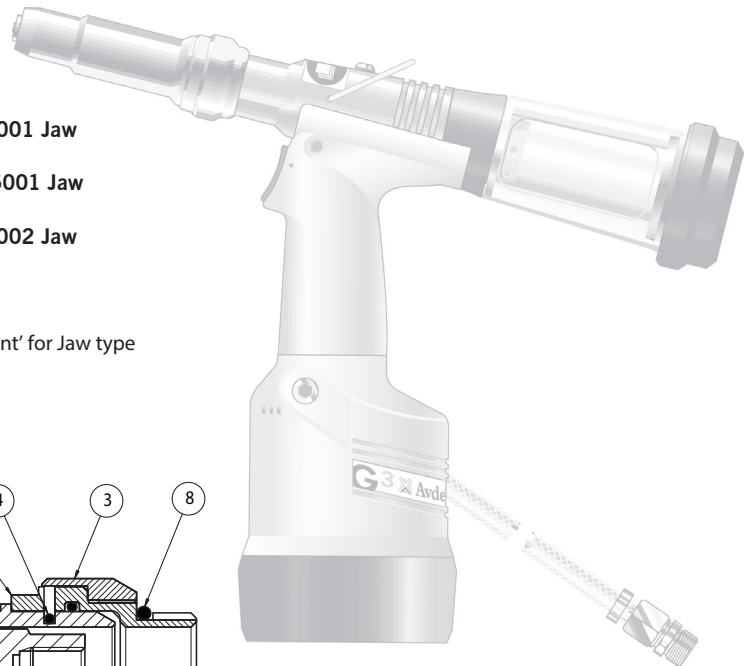
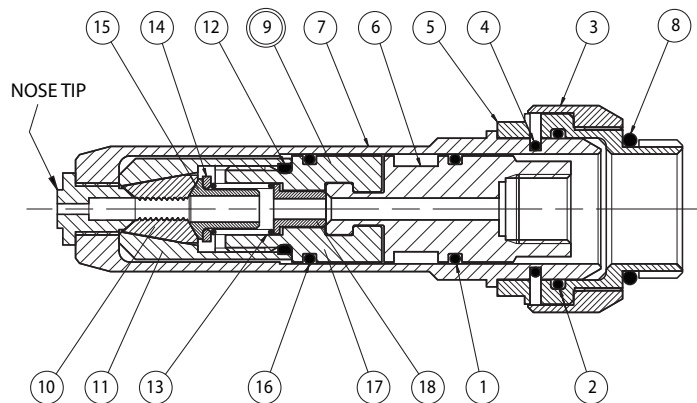

		GENESIS® TOOL TYPE		
		nG1/nG2/nG2s G2/ G2s/ G2HD	nG3/nG4 G3/ G4/ G3HD/ G4HD	nG3/nG4 G3/ G4/ G3HD/ G4HD
	<b>QUICK RELEASE NOSE ASSEMBLY</b>	<b>71210-20310</b>	<b>71220-20310</b>	<b>71220-20350</b>
1	'O' Ring	07003-00277	07003-00369	07003-00369
2	'O' Ring	07003-00342	07003-00368	07003-00368
3	Spring Cover	71210-20311	71220-20311	71220-20311
4	'U' Spring	71210-20312	71220-20312	71220-20312
5	Nose Case Adaptor	71210-20313	71220-20313	71220-20313
6	'T' Adaptor	71210-20314	71220-20314	71220-20314
7	Quick Release Nose Casing	71210-20316	71220-20316	71220-20316
8	'O' Ring	07003-00349	07003-00349	07003-00349
9	* Nose Equipment Cartridge	71210-20320	71220-20320	71220-20360
10	Jaw Set	71210-15001	71210-15001	07612-02002
11	Jaw Housing	07340-00304	07340-00304	07612-02003
12	Locking Ring	07340-00327	07340-00327	07340-00327
13	Spring	07500-00418	07500-00418	07500-00418
14	Buffer	71210-05001	71210-05001	71210-05001
15	Jaw Spreader	07498-04502	07498-04502	07498-04502
16	'O' Ring	07003-00277	07003-00369	07003-00369
17	Jaw Spreader Housing 'T'	71210-20321	71220-20321	71220-20321
18	Detent Sleeve	71210-20322	71220-20322	71220-20322

\* Nose Equipment Cartridge comprising Items 10 to 18

## Genesis® Quick Release Nose Equipment

### To Prepare Base Tool to Accept Quick Release Nose Equipment

---

(Refer to the relevant Genesis® Tool Instruction Manual.)

- For nG3/4, G3/4 and G2/G2s tools remove Jaw Spreader Housing 71210-02101.
- For nG1, nG2 and nG2s tools remove 'T' Adaptor 71213-02020.
- Replace above part with 'T' Adaptor (item **6**). **Note:** For nG3/4 tools 'T' Adaptor (item **6**) is assembled through Nose Case Adaptor Assembly (items **2, 3, 4, 5** and **8**).
- Screw the Nose Case Adaptor Assembly (items **2, 3, 4, 5** and **8**) into the front of the tool.
- The Nose Equipment Cartridge (item **9**) is assembled onto the 'T' Adaptor (item **6**) by sliding in a plane normal to the Piston.
- Push the Quick Release Nose Casing (item **7**) into the Nose Case Adaptor (item **5**) ensuring flats are aligned, this locks the Quick Release Nose Casing into position.

### To Remove the Quick Release Nose Equipment

---

- Rotate the Quick Release Nose Casing (item **7**) through 90 degrees and pull out of the Nose Case Adaptor (item **5**).
- To release the Nose Equipment Cartridge (item **9**) from 'T' Adaptor (item **6**) slide cartridge in a plane normal to the head Piston.

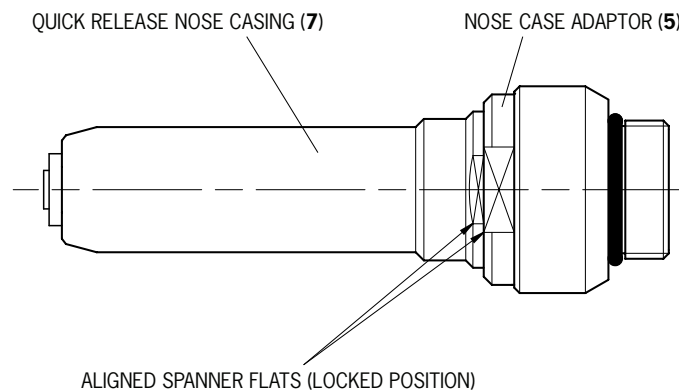

Item numbers in **bold** refer to the Parts List on the front page.



Notes



Since 1922



Avdel® iForm™

Since 1936

2010



Our Technology, Your Success

#### AUSTRALIA

##### Infastech (Australia) Pty Ltd.

891 Wellington Road  
Rowville  
Victoria 3178  
Tel: +61 3 9765 6400  
Fax: +61 3 9765 6445  
info@infastech.com.au

#### CANADA

##### Avdel Canada Limited

1030 Lorimar Drive  
Mississauga  
Ontario L5S 1R8  
Tel: +1 905 364 0664  
Fax: +1 905 364 0678  
infoAvdel-Canada@infastech.com

#### CHINA

##### Infastech (China) Ltd.

RM 1708, 17/F., Nanyang Plaza,  
57 Hung To Rd., Kwun Tong  
Hong Kong  
Tel: +852 2950 0631  
Fax: +852 2950 0022  
infochina@infastech.com

#### FRANCE

##### Avdel France S.A.S.

33 bis, rue des Ardennes  
BP4  
75921 Paris Cedex 19  
Tel: +33 (0) 1 4040 8000  
Fax: +33 (0) 1 4208 2450  
AvdelFrance@infastech.com

#### GERMANY

##### Avdel Deutschland GmbH

Klusriede 24  
30851 Langenhagen  
Tel: +49 (0) 511 7288 0  
Fax: +49 (0) 511 7288 133  
AvdelDeutschland@infastech.com

#### INDIA

##### Infastech Fastening Technologies

##### India Private Limited

Plot No OZ-14, Hi Tech SEZ,  
SIPCOT Industrial Growth Center,  
Oragadam, Sriperumbudur Taluk,  
Kanchipuram District,  
602105 Tamilnadu  
Tel: +91 44 4711 8001  
Fax: +91 44 4711 8009  
info-in@infastech.com

#### ITALY

##### Avdel Italia S.r.l.

Viale Lombardia 51/53  
20047 Brugherio (MI)  
Tel: +39 039 289911  
Fax: +39 039 2873079  
vendite@infastech.com

#### JAPAN

##### Infastech Kabushiki Kaisha

Center Minami SKY,  
3-1 Chigasaki-Chuo, Tsuzuki-ku,  
Yokohama-city,  
Kanagawa Prefecture  
Japan 224-0032  
Tel: +81 45 947 1200  
Fax: +81 45 947 1205  
info@infastech.co.jp

#### MALAYSIA

##### Infastech (Malaysia) Sdn Bhd

Lot 63, Persiaran Bunga Tanjung 1,  
Senawang Industrial Park  
70400 Seremban  
Negeri Sembilan  
Tel: +606 676 7168  
Fax: +606 676 7101  
info-my@infastech.com

#### SINGAPORE

##### Infastech (Singapore) Pte Ltd.

31 Kaki Bukit Road 3  
#05-03/06 Techlink  
Singapore, 417818  
Tel: +65 6372 5653  
Fax: +65 6744 5643  
info-sg@infastech.com

#### SOUTH KOREA

##### Infastech (Korea) Ltd.

212-4, Suyang-Ri,  
Silchon-Eup, Kwangju-City,  
Kyunggi-Do, Korea, 464-874  
Tel: +82 31 798 6340  
Fax: +82 31 798 6342  
info@infastech.co.kr

#### SPAIN

##### Avdel Spain S.A.

C/ Puerto de la Morcuera, 14  
Poligono Industrial Prado Overa  
Ctra. de Toledo, km 7,8  
28919 Leganés (Madrid)  
Tel: +34 91 3416767  
Fax: +34 91 3416740  
ventas@infastech.com

#### TAIWAN

##### Infastech/Tri-Star Limited

No 269-7, Baodong Rd,  
Guanmiao Township,  
71841 Tainan County,  
Taiwan, R.O.C  
Tel: +886 6 596 5798 (ext 201)  
Fax: +886 6 596 5758  
info-tw@infastech.com

#### UNITED KINGDOM

##### Avdel UK Limited

Pacific House  
2 Swiftfields  
Watchmead Industrial Estate  
Welwyn Garden City  
Hertfordshire AL7 1LY  
Tel: +44 (0) 1707 292000  
Fax: +44 (0) 1707 292199  
enquiries@infastech.com

#### USA

##### Avdel USA LLC

614 NC Highway 200 South  
Stanfield, North Carolina 28163  
Tel: +1 704 888 7100  
Fax: +1 704 888 0258  
infoAvdel-USA@infastech.com

Data Sheet No	Issue	Change Note No.
07900-00798	A3	08/198
	B	11/019

[www.avdel-global.com](http://www.avdel-global.com)  
[www.infastech.com](http://www.infastech.com)

Autosert® (equipment), Avbolt®, Avdel®, Avdelmate®, Avdel TX2000®, Avdelok®, Avex®, Avibulb®, Avinox®, Avinut™, Avlug®, Avmatic®, Avplas®, Avseal®, Avsert®, Avtainer®, Avtronic®, Briv®, Bulbex®, Chobert®, Eurosert®, Fastriv®, Finsert®, Genesis®, Grovit®, Hemlok®, Hexsert®, Holding your world together®, Hydra®, Interlock®, Klamp-Tite®, KlampTite KTR®, Kvex®, Maxlok®, Monobolt®, Monobulb®, Neobolt®, Nutsert®, Nutsert SQ®, Portariv®, Rivmatic®, Rivscrew®, Speed Fastening®, Squaresert®, Stavex®, Supersert®, Thin Sheet Nutsert®, Titan®, T-Lok®, TLR®, TSN®, TX2000®, Versa-Nut®, Viking® and Viking 360® are trademarks of Avdel UK Limited. Infastech™ and Our Technology, Your Success™ are trademarks of Infastech Intellectual Properties Pte Ltd. The names and logos of other companies mentioned herein may be trademarks of their respective owners. This document is for informational purposes only. Infastech makes no warranties, expressed or implied, in this document. Data shown is subject to change without prior notice as a result of continuous product development and improvement policy. Your local Avdel representative is at your disposal should you need to confirm latest information.