

Genesis®

Næseudstyr med hurtigudløser

NÆSEUDSTYR MED HURTIGUDLØSER:

71210-20310 - Enhed inklusive 71210-15001 Kæbe
(til værktøjstype G2)

71220-20310 - Enhed inklusive 71210-15001 Kæbe
(til værktøjstype G3/4)

71220-20350 - Enhed med 07612-02002 Kæbe
(til værktøjstype G3/4)

Bemærk! Se brugsanvisningen til værktøjet 'Næseudstyr' for at finde oplysninger om kæbetype og den korrekte næsespids til den angivne fastspændingsanordning.

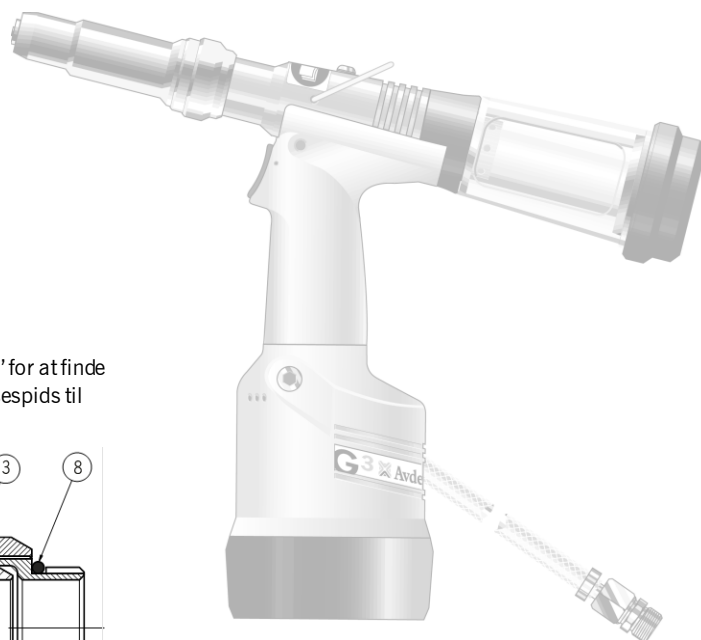
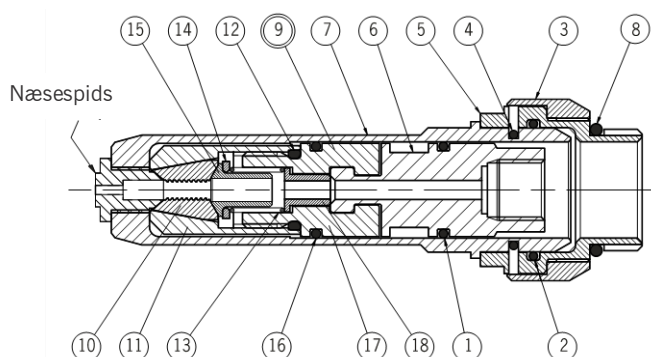

		GENESIS® VÆRKTØJSTYPE		
ENHED	BESKRIVELSE	nG1/nG2/nG2s G2/G2s/G2HD 71210-20310	nG3/nG4 G3/G4/G3HD/G4HD 71220-20310	nG3/nG4 G3/G4/G3HD/G4HD 71220-20350
	NÆSEENHED MED HURTIGUDLØSER			
1	O-ring	07003-00277	07003-00369	07003-00369
2	O-ring	07003-00342	07003-00368	07003-00368
3	Fjederdæksel	71210-20311	71220-20311	71220-20311
4	U-fjeder	71210-20312	71220-20312	71220-20312
5	Adapter til næsekappe	71210-20313	71220-20313	71220-20313
6	T-adapter	71210-20314	71220-20314	71220-20314
7	Næsekappe med hurtigudløser	71210-20316	71220-20316	71220-20316
8	O-ring	07003-00349	07003-00349	07003-00349
9	*Kassette til næseudstyr	71210-20320	71220-20320	71220-20360
10	Kæbesæt	71210-15001	71210-15001	07612-02002
11	Kæbehus	07340-00304	07340-00304	07612-02003
12	Låserring	07340-00327	07340-00327	07340-00327
13	Fjeder	07500-00418	07500-00418	07500-00418
14	Buffer	71210-05001	71210-05001	71210-05001
15	Kæbespreder	07498-04502	07498-04502	07498-04502
16	O-ring	07003-00277	07003-00369	07003-00369
17	Hus 'T' til kæbespreder	71210-20321	71220-20321	71220-20321
18	Holdemuffe	71210-20322	71220-20322	71220-20322

* Kassette til næseudstyr indeholdende enhed 10 til 18

Genesis® næseudstyr med hurtigudløser

Klargøring af basisværktøjet til brug af næseudstyr med hurtigudløser

(Se den relevante brugsanvisning til Genesis® -værktøjet).

- Ved brug af værktøjsenhederne nG3/4, G3/4 og G2/G2s skal kæbesprederhuset 71210-02101 afmonteres.
- Ved brug af værktøjsenhederne nG1, nG2 og nG2s skal T-adapter 71213-02020 afmonteres.
- Erstat ovenstående del med T-adapteren (enhed **6**). **Bemærk!** Ved brug af værktøjsenhederne nG3/4 skal T-adapteren (enhed **6**) monteres gennem adapterenheden til næsekappen (enhed **2, 3, 4, 5** og **8**).
- Skru adapterenheden til næsekappen (enhed **2, 3, 4, 5** og **8**) i på værktøjets front.
- Kassetten til næseudstyr (enhed **9**) sættes på T-adapteren (enhed **6**) ved at indføre den i et plan, der er normalt i forhold til stemplet.
- Tryk næsekappen med hurtigudløser (enhed **7**) ind i adapteren til næsekappen (enhed **5**). Kontrollér, at fladerne flugter. Næsekappen med hurtigudløser låses nu på plads.

Afmontering af næseudstyr med hurtigudløser

- Drej næsekappen med hurtigudløser (enhed **7**) 90 grader, og træk adapteren til næsekappen ud (enhed **5**).
- Kassetten til næseudstyr (enhed **9**) løsnes fra T-adapteren (enhed **6**) ved at skubbe kassetten i et plan, der er normalt i forhold til hovedstempet.

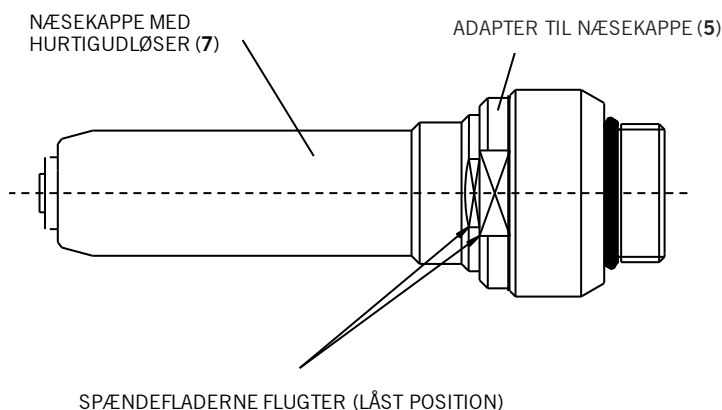

Enhedsnumrene med **fed** henviser til listen over dele på forsiden.



Since 1922



Avdel® iForm™

Since 1936

2010



Our Technology, Your Success

AUSTRALIEN**Infastech (Australia) Pty Ltd.**

891 Wellington Road
Rowville
Victoria 3178
Tel: +61 3 9765 6400
Fax: +61 3 9765 6445
info@infastech.com.au

CANADA**Avdel Canada Limited**

1030 Lorimar Drive
Mississauga
Ontario L5S 1R8
Tel: +1 905 364 0664
Fax: +1 905 364 0678
infoAvdel-Canada@infastech.com

KINA**Infastech (China) Ltd.**

RM 1708, 17/F., Nanyang Plaza,
57 Hung To Rd., Kwun Tong
Hong Kong
Tel: +852 2950 0631
Fax: +852 2950 0022
infochina@infastech.com

FRANKRIG**Avdel France S.A.S.**

33 bis, rue des Ardennes
BP4
75921 Paris Cedex 19
Tel: +33 (0) 1 4040 8000
Fax: +33 (0) 1 4208 2450
AvdelFrance@infastech.com

TYSKLAND**Avdel Deutschland GmbH**

Klusriede 24
30851 Langenhagen
Tel: +49 (0) 511 7288 0
Fax: +49 (0) 511 7288 133
AvdelDeutschland@infastech.com

INDIEN**Infastech Fastening Technologies****India Private Limited**

Plot No OZ-14, Hi Tech SEZ,
SIPCOT Industrial Growth Center,
Oragadam, Sriperumbudur Taluk,
Kanchipuram District,
602105 Tamilnadu
Tel: +91 44 4711 8001
Fax: +91 44 4711 8009
info-in@infastech.com

ITALIEN**Avdel Italia S.r.l.**

Viale Lombardia 51/53
20047 Brugherio (MI)
Tel: +39 039 289911
Fax: +39 039 2873079
vendite@infastech.com

JAPAN**Infastech Kabushiki Kaisha**

Center Minami SKY,
3-1 Chigasaki-Chuo, Tsuzuki-ku,
Yokohama-city,
Kanagawa Prefecture
Japan 224-0032
Tel: +81 45 947 1200
Fax: +81 45 947 1205
info@infastech.co.jp

MALAYSIA**Infastech (Malaysia) Sdn Bhd**

Lot 63, Persiaran Bunga Tanjung 1,
Senawang Industrial Park
70400 Seremban
Negeri Sembilan
Tel: +606 676 7168
Fax: +606 676 7101
info-my@infastech.com

SINGAPORE**Infastech (Singapore) Pte Ltd.**

31 Kaki Bukit Road 3
#05-03/06 Techlink
Singapore, 417818
Tel: +65 6372 5653
Fax: +65 6744 5643
info-sg@infastech.com

SYDKOREA**Infastech (Korea) Ltd.**

212-4, Suyang-Ri,
Silchon-Eup, Kwangju-City,
Kyunggi-Do, Korea, 464-874
Tel: +82 31 798 6340
Fax: +82 31 798 6342
info@infastech.co.kr

SPANIEN**Avdel Spain S.A.**

C/ Puerto de la Morcuera, 14
Poligono Industrial Prado Overa
Ctra. de Toledo, km 7,8
28919 Leganés (Madrid)
Tel: +34 91 3416767
Fax: +34 91 3416740
ventas@infastech.com

TAIWAN**Infastech/Tri-Star Limited**

No 269-7, Baodong Rd,
Guanmiao Township,
71841 Tainan County,
Taiwan, R.O.C
Tel: +886 6 596 5798 (ext 201)
Fax: +886 6 596 5758
info-tw@infastech.com

STORBRIANNIEN**Avdel UK Limited**

Pacific House
2 Swiftfields
Watchmead Industrial Estate
Welwyn Garden City
Hertfordshire AL7 1LY
Tel: +44 (0) 1707 292000
Fax: +44 (0) 1707 292199
enquiries@infastech.com

USA**Avdel USA LLC**

614 NC Highway 200 South
Stanfield, North Carolina 28163
Tel: +1 704 888 7100
Fax: +1 704 888 0258
infoAvdel-USA@infastech.com

Manual No.	Issue	Change Note No.
07900-00798	A	07/044
	A2	07/103
	B	11/019

www.avdel-global.com
www.infastech.com

Autosert® (equipment), Avbolt®, Avdel®, Avdelmate®, Avdel TX2000®, Avdelok®, Avex®, Avibulb®, Avinox®, Avinut™, Avlug®, Avmatic®, Avplas®, Avseal®, Avsert®, Avtainer®, Avtronic®, Briv®, Bulbex®, Chobert®, Eurosert®, Fastriv®, Finsert®, Genesis®, Grovit®, Hemlok®, Hexsert®, Holding your world together®, Hydra®, Interlock®, Klamp-Tite®, KlampTite KTR®, Kvex®, Maxlok®, Monobolt®, Monobulb®, Neobolt®, Nutsert®, Nutsert SQ®, Portariv®, Rivmatic®, Rivscrew®, Speed Fastening®, Squaresert®, Stavex®, Supersert®, Thin Sheet Nutsert®, Titan®, T-Lok®, TLR®, TSN®, TX2000®, Versa-Nut®, Viking® og Viking 360® er varemærker tilhørende Avdel UK Limited. Infastech™ og Our Technology, Your Success™ er varemærker tilhørende Infastech Intellectual Properties Pte Ltd. Navne og logoer fra andre virksomheder, som er nævnt i dette dokument, kan være varemærker tilhørende deres respektive ejere. Dette dokument har alene et informativt formål. Infastech yder ingen garantier, hverken direkte eller indirekte, i dette dokument. De viste data kan ændres uden forudgående varsel som følge af vores politik om løbende produktudvikling og -forbedring. Du er velkommen til at kontakte din lokale Avdel-repræsentant, hvis du har brug for yderligere oplysninger.

Genesis®

Quick Release Nose Equipment

QUICK RELEASE NOSE ASSEMBLIES:

71210-20310 - Assembly incorporating 71210-15001 Jaw
(for G2 tool types)

71220-20310 - Assembly incorporating 71210-15001 Jaw
(for G3/4 tool types)

71220-20350 - Assembly incorporating 07612-02002 Jaw
(for G3/4 tool types)

Note: Refer to tool Instruction Manual 'Nose Equipment' for Jaw type and appropriate Nose Tip for specified fastener.

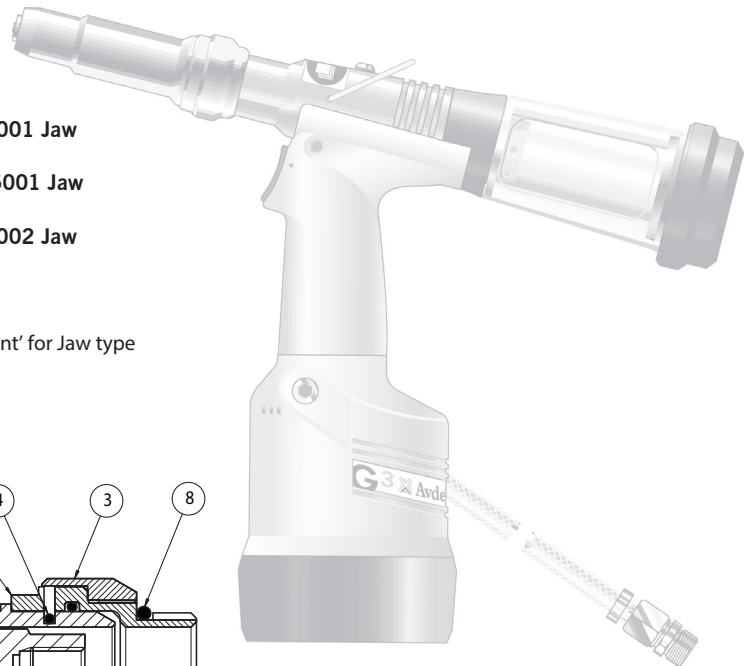
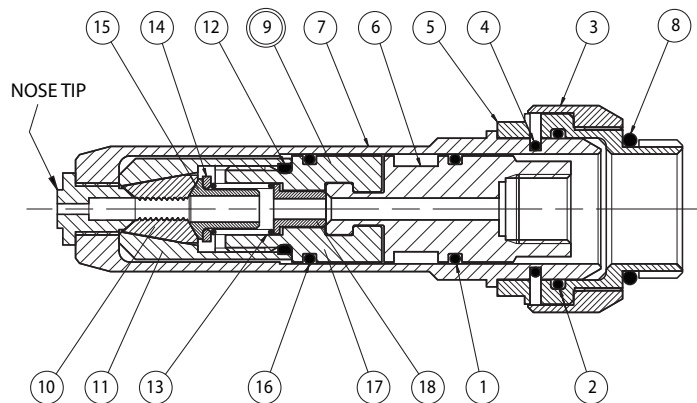

		GENESIS® TOOL TYPE		
		nG1/nG2/nG2s G2/ G2s/ G2HD	nG3/nG4 G3/ G4/ G3HD/ G4HD	nG3/nG4 G3/ G4/ G3HD/ G4HD
	QUICK RELEASE NOSE ASSEMBLY	71210-20310	71220-20310	71220-20350
1	'O' Ring	07003-00277	07003-00369	07003-00369
2	'O' Ring	07003-00342	07003-00368	07003-00368
3	Spring Cover	71210-20311	71220-20311	71220-20311
4	'U' Spring	71210-20312	71220-20312	71220-20312
5	Nose Case Adaptor	71210-20313	71220-20313	71220-20313
6	'T' Adaptor	71210-20314	71220-20314	71220-20314
7	Quick Release Nose Casing	71210-20316	71220-20316	71220-20316
8	'O' Ring	07003-00349	07003-00349	07003-00349
9	* Nose Equipment Cartridge	71210-20320	71220-20320	71220-20360
10	Jaw Set	71210-15001	71210-15001	07612-02002
11	Jaw Housing	07340-00304	07340-00304	07612-02003
12	Locking Ring	07340-00327	07340-00327	07340-00327
13	Spring	07500-00418	07500-00418	07500-00418
14	Buffer	71210-05001	71210-05001	71210-05001
15	Jaw Spreader	07498-04502	07498-04502	07498-04502
16	'O' Ring	07003-00277	07003-00369	07003-00369
17	Jaw Spreader Housing 'T'	71210-20321	71220-20321	71220-20321
18	Detent Sleeve	71210-20322	71220-20322	71220-20322

* Nose Equipment Cartridge comprising Items 10 to 18

Genesis® Quick Release Nose Equipment

To Prepare Base Tool to Accept Quick Release Nose Equipment

(Refer to the relevant Genesis® Tool Instruction Manual.)

- For nG3/4, G3/4 and G2/G2s tools remove Jaw Spreader Housing 71210-02101.
- For nG1, nG2 and nG2s tools remove 'T' Adaptor 71213-02020.
- Replace above part with 'T' Adaptor (item **6**). **Note:** For nG3/4 tools 'T' Adaptor (item **6**) is assembled through Nose Case Adaptor Assembly (items **2, 3, 4, 5** and **8**).
- Screw the Nose Case Adaptor Assembly (items **2, 3, 4, 5** and **8**) into the front of the tool.
- The Nose Equipment Cartridge (item **9**) is assembled onto the 'T' Adaptor (item **6**) by sliding in a plane normal to the Piston.
- Push the Quick Release Nose Casing (item **7**) into the Nose Case Adaptor (item **5**) ensuring flats are aligned, this locks the Quick Release Nose Casing into position.

To Remove the Quick Release Nose Equipment

- Rotate the Quick Release Nose Casing (item **7**) through 90 degrees and pull out of the Nose Case Adaptor (item **5**).
- To release the Nose Equipment Cartridge (item **9**) from 'T' Adaptor (item **6**) slide cartridge in a plane normal to the head Piston.

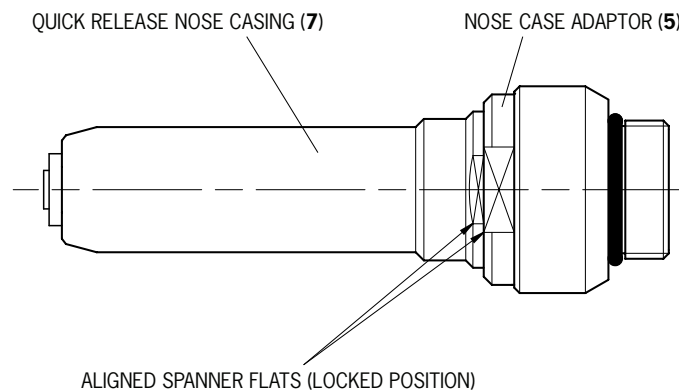

Item numbers in **bold** refer to the Parts List on the front page.



Notes



Since 1922



Avdel® iForm™

Since 1936

2010



Our Technology, Your Success

AUSTRALIA

Infastech (Australia) Pty Ltd.

891 Wellington Road
Rowville
Victoria 3178
Tel: +61 3 9765 6400
Fax: +61 3 9765 6445
info@infastech.com.au

CANADA

Avdel Canada Limited

1030 Lorimar Drive
Mississauga
Ontario L5S 1R8
Tel: +1 905 364 0664
Fax: +1 905 364 0678
infoAvdel-Canada@infastech.com

CHINA

Infastech (China) Ltd.

RM 1708, 17/F., Nanyang Plaza,
57 Hung To Rd., Kwun Tong
Hong Kong
Tel: +852 2950 0631
Fax: +852 2950 0022
infochina@infastech.com

FRANCE

Avdel France S.A.S.

33 bis, rue des Ardennes
BP4
75921 Paris Cedex 19
Tel: +33 (0) 1 4040 8000
Fax: +33 (0) 1 4208 2450
AvdelFrance@infastech.com

GERMANY

Avdel Deutschland GmbH

Klusriede 24
30851 Langenhagen
Tel: +49 (0) 511 7288 0
Fax: +49 (0) 511 7288 133
AvdelDeutschland@infastech.com

INDIA

Infastech Fastening Technologies

India Private Limited

Plot No OZ-14, Hi Tech SEZ,
SIPCOT Industrial Growth Center,
Oragadam, Sriperumbudur Taluk,
Kanchipuram District,
602105 Tamilnadu
Tel: +91 44 4711 8001
Fax: +91 44 4711 8009
info-in@infastech.com

ITALY

Avdel Italia S.r.l.

Viale Lombardia 51/53
20047 Brugherio (MI)
Tel: +39 039 289911
Fax: +39 039 2873079
vendite@infastech.com

JAPAN

Infastech Kabushiki Kaisha

Center Minami SKY,
3-1 Chigasaki-Chuo, Tsuzuki-ku,
Yokohama-city,
Kanagawa Prefecture
Japan 224-0032
Tel: +81 45 947 1200
Fax: +81 45 947 1205
info@infastech.co.jp

MALAYSIA

Infastech (Malaysia) Sdn Bhd

Lot 63, Persiaran Bunga Tanjung 1,
Senawang Industrial Park
70400 Seremban
Negeri Sembilan
Tel: +606 676 7168
Fax: +606 676 7101
info-my@infastech.com

SINGAPORE

Infastech (Singapore) Pte Ltd.

31 Kaki Bukit Road 3
#05-03/06 Techlink
Singapore, 417818
Tel: +65 6372 5653
Fax: +65 6744 5643
info-sg@infastech.com

SOUTH KOREA

Infastech (Korea) Ltd.

212-4, Suyang-Ri,
Silchon-Eup, Kwangju-City,
Kyunggi-Do, Korea, 464-874
Tel: +82 31 798 6340
Fax: +82 31 798 6342
info@infastech.co.kr

SPAIN

Avdel Spain S.A.

C/ Puerto de la Morcuera, 14
Poligono Industrial Prado Overa
Ctra. de Toledo, km 7,8
28919 Leganés (Madrid)
Tel: +34 91 3416767
Fax: +34 91 3416740
ventas@infastech.com

TAIWAN

Infastech/Tri-Star Limited

No 269-7, Baodong Rd,
Guanmiao Township,
71841 Tainan County,
Taiwan, R.O.C
Tel: +886 6 596 5798 (ext 201)
Fax: +886 6 596 5758
info-tw@infastech.com

UNITED KINGDOM

Avdel UK Limited

Pacific House
2 Swiftfields
Watchmead Industrial Estate
Welwyn Garden City
Hertfordshire AL7 1LY
Tel: +44 (0) 1707 292000
Fax: +44 (0) 1707 292199
enquiries@infastech.com

USA

Avdel USA LLC

614 NC Highway 200 South
Stanfield, North Carolina 28163
Tel: +1 704 888 7100
Fax: +1 704 888 0258
infoAvdel-USA@infastech.com

Data Sheet No	Issue	Change Note No.
07900-00798	A3	08/198
	B	11/019

www.avdel-global.com
www.infastech.com

Autosert® (equipment), Avbolt®, Avdel®, Avdelmate®, Avdel TX2000®, Avdelok®, Avex®, Avibulb®, Avinox®, Avinut™, Avlug®, Avmatic®, Avplas®, Avseal®, Avsert®, Avtainer®, Avtronic®, Briv®, Bulbex®, Chobert®, Eurosert®, Fastriv®, Finsert®, Genesis®, Grovit®, Hemlok®, Hexsert®, Holding your world together®, Hydra®, Interlock®, Klamp-Tite®, KlampTite KTR®, Kvex®, Maxlok®, Monobolt®, Monobulb®, Neobolt®, Nutsert®, Nutsert SQ®, Portariv®, Rivmatic®, Rivscrew®, Speed Fastening®, Squaresert®, Stavex®, Supersert®, Thin Sheet Nutsert®, Titan®, T-Lok®, TLR®, TSN®, TX2000®, Versa-Nut®, Viking® and Viking 360® are trademarks of Avdel UK Limited. Infastech™ and Our Technology, Your Success™ are trademarks of Infastech Intellectual Properties Pte Ltd. The names and logos of other companies mentioned herein may be trademarks of their respective owners. This document is for informational purposes only. Infastech makes no warranties, expressed or implied, in this document. Data shown is subject to change without prior notice as a result of continuous product development and improvement policy. Your local Avdel representative is at your disposal should you need to confirm latest information.